

# R19IB3S-67FTP(HB)

19" Intel® Celeron® N2930 G-WIN Full IP67 Series Panel PC



## KEY FEATURES

- Totally sealed Full IP67 Design
- High performance / low power Intel® Celeron® N2930 2.16GHz Processor
- Anti-scratch 19-inch sunlight viewable 400 nits LCD panel (Optional for 1000 nits High Brightness)
- -10 to 60°C operating temperature
- Fanless, streamlined enclosure for highly efficient heat dissipation
- Touch screen control button to enable/disable touch screen interface
- Rugged Front Anti-Impact Design
- Front control membrane keys Lockable by software
- Optical Bonding with Panel & Touch Screen to increase the clarity and transparency



## SPECIFICATIONS

System Specification			
<b>Processor</b>	Intel® Celeron® N2930 (2M Cache, up to 2.16 GHz)	<b>Memory</b>	1 x SO-DIMM, DDR3L 1600 MHz, 4GB 8GB (Optional)
<b>Storage</b>	1 x mSATA SSD 64GB. mSATA SSD up to 512GB. (Optional)	<b>Ethernet controller</b>	2 x Intel® Ethernet Controller I210-AT
<b>Security</b>	TPM 2.0	<b>Operating System</b>	Windows 7 Embedded Systems (Optional) Windows 10 IoT Enterprise (Optional) Linux Ubuntu 18.04 (Optional)
<b>WLAN</b>	802.11 a/b/g/n/ac (Optional)	<b>BT</b>	BT Support (Optional)
Display			
<b>Resolution</b>	1280x1024	<b>Size</b>	19.0 inches
<b>Contrast Ratio</b>	1000:1	<b>Panel Brightness</b>	350 nits 1000 nits(Optional)
<b>View Angles</b>	85,85,80,80	<b>Touch / Glass</b>	Projected Capacitive Multi Touch Screen Bonding With Panel
<b>Optional function</b>	High brightness Panel for sunlight readable (Optional)		
Mechanical			
<b>Dimension</b>	474 x 410 x 111 mm	<b>Mounting</b>	Panel mount VESA Mount
<b>Enclosure</b>	Aluminum Housing	<b>Cooling System</b>	Fanless design
<b>Cut out</b>	462 x 386mm		
Environment			
<b>Operating Humidity</b>	10% to 90% (non-condensing)	<b>Operating Temperature</b>	-15~55°C
<b>Storage Temperature</b>	-30~70°C	<b>Shock</b>	30g for 18ms, 300m/s <sup>2</sup>
<b>Vibration</b>	1.60/1.96/2.18 g rms for XYZ / 5-500Hz	<b>IP rating</b>	IP67
Certification			
<b>Certification</b>	CE, FCC Class B MIL810F/ IEC60068-2-27 for		

IO Ports			
<b>USB Port</b>	1 x M12 waterproof connector for 2 x USB2.0 1 x Waterproof USB Type-A Connector with cover	<b>Serial Port</b>	1 x M12 waterproof connector for RS232
<b>LAN</b>	1 x waterproof Giga LAN RJ45 connector	<b>Indicator</b>	1 x LED Indicator for power 1 x LED Indicator for storage 1 x LED Indicator for heater 1 x LED Indicator for LAN 1 x LED Indicator for lock touch
Control			
<b>Button</b>	1 x Power Button 1 x Brightness up Button 1 x Brightness down Button 1 x Button for locking touch function 1 x Programmable function key		
Accessory			
<b>Accessory</b>	External open wire Power cable with waterproof connector External USB cable with waterproof connector External COM cable with waterproof connector External LAN cable with waterproof connector Waterproof caps RJ45 female-female converter Driver CD & Manual Mounting clips VESA screws	<b>Optional Accessory</b>	100~240V AC to DC Adapter with power cord (Optional)

**DIMENSIONS** UNIT:MM

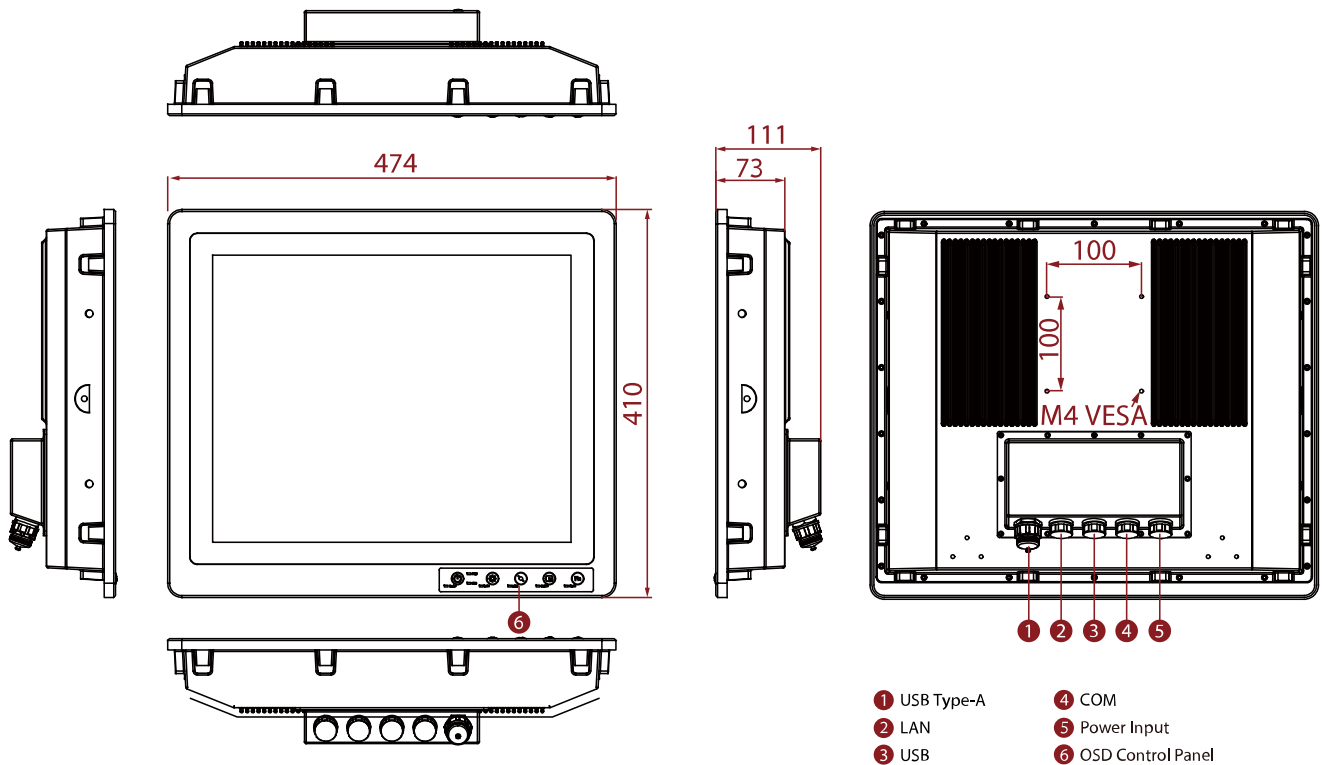

## NOTE

1. This is a simplified drawing and some components are not marked in detail.
2. Windows 10 operating system requires installing a new version of BIOS and OS image.
3. Windows 7 does not support the TPM 2.0 function.
4. Please contact our sales representative if you need further product information.
5. All specifications are subject to change without prior notice.
6. The product shown in this datasheet is a standard model. For diagrams that contain customized or optional I/O, please contact the Winmate Sales Team for more information.