

tBOX321-870-FL

Fanless Embedded System with Intel® Core™ i Processor and Intel® QM77 Chipset for Railway PC

NEW

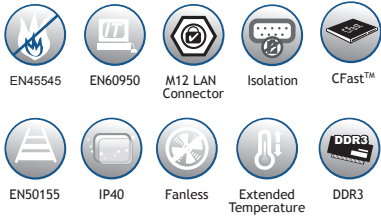
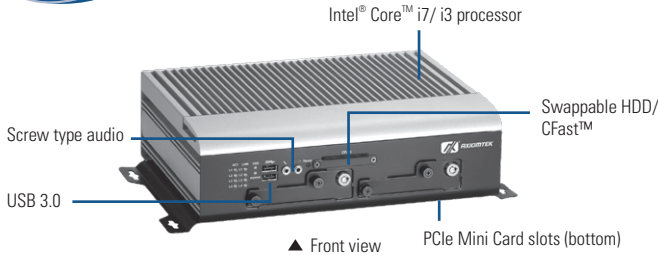

Specifications

Standard Color	Silver-Black
Construction	Aluminum extrusion and heavy-duty steel, IP40
CPU	3rd Generation Intel® Core™ i processor onboard; 3rd Gen. Intel® Core™ i7-3517UE (1.7 GHz) or 3rd Gen. Intel® Core™ i3-3217UE (1.6 GHz)
System Memory	DDR3-1600 4 GB (i7) or 2 GB (i3) DRAM Onboard
Chipset	Intel® QM77
BIOS	AMI UEFI BIOS with OA 3.0 built
System I/O Outlet	4 x 10/100/1000Mbps Ethernet (M12 female A-coded) 4 x isolated RS-232/422/485 (COM 1 ~ 4) 1 x isolated DI/DO (4-IN/4-OUT) 2 x USB 2.0 (rear side) (M12 connector) 2 x USB 3.0 (front side) 2 x Audio (Mic-in/Line-out) (M12 and screw type) 1 x VGA 1 x DVI 1 x VDC power input connector (M12 connector) 1 x reset switch 1 x power switch 4 x antenna opening
Watchdog Timer	255 levels, 0 ~ 255 sec.
Storage	2 x 2.5" SATA HDD (Removable and with lock protection) Supports RAID 0/1 1 x CFast™
Expansion Interface	3 x PCI Express Mini Card 1 x SIM card slot
System Indicator	1 x green LED for system power on 1 x blue LED for HDD active 1 x green LED for LAN1 link 1 x green/yellow LED for LAN 1 speed 1 x green LED for LAN2 link 1 x green/yellow LED for LAN 2 speed 1 x green LED for LAN3 link 1 x green/yellow LED for LAN 3 speed 1 x green LED for LAN4 link 1 x green/yellow LED for LAN 4 speed
Power Supply	Power input : 14VDC ~ 32VDC (isolation) Typical : 24VDC Power interruption class S2

Features

- 3rd Generation Intel® Core™ i7 1.7 GHz or Intel® Core™ i3 1.6 GHz processor onboard
- Intel® QM77 PCH
- High performance DDR3-1600 4 GB memory onboard
- Fanless operation
- Operating temperature range of -40°C ~ +70°C
- Isolated RS-232/422/485 and DIO
- Support USB 3.0 and SATA3
- 2 removable & lockable 2.5" SATA HDD and 1 CFast™
- 3 internal PCI Express Mini Card slot and 1 SIM slot
- Lockable I/O interface and M12 LAN and USB connector
- Comply to fire protection of railway vehicles Europe standard PrCEN TS 45545-2



Power Consumption	6.67A @ 12V / 3.34A @ 24V / 2.5A @ 32V
Operating Temperature	-40°C ~ +70°C (-40°C ~ +158°C) W/T SSD -25°C ~ +55°C (-13°C ~ +131°C) W/T HDD
Storage Temperature	-40°C ~ +80°C (-40°C ~ +176°C)
Humidity	10% ~ 90%, non-condensing
Vibration Endurance	5 Grms w/ CFast (5-500Hz, X, Y, Z directions) 1 Grms w/ HDD (5-500Hz, X, Y, Z directions)
Dimensions	288 mm (11.33") (W) x 211 mm (8.3") (D) x 85.7 mm (3.37") (H)
Weight (net/gross)	5.5 kg (12.12 lb)/6.5 kg (14.33 lb)
Certification	CE (Class A), EN50155, EN50121, EN45545, EN60950 compliance
EOS Support	WES 8, WES 7, Windows® 7/8, Linux

*XPE: Windows XP Embedded

Ordering Information

Standard	
tBOX321-870-FL-i7-DC	Fanless Embedded System with 3rd Generation Intel® Core™ i7 processor, 4 GB DDR3-1600, 4 10/100/1000Mbps Ethernet (M12), 4 isolated COM, CFast™
tBOX321-870-FL-i3-DC	Fanless Embedded System with 3rd Generation Intel® Core™ i3 processor

Optional	
2.5" SATA HDD/SSD	16 GB or above
CFast™	1 GB or above
3G module	
Wifi module	
Wifi+Bluetooth	
GPS module	
M12 Giga LAN cable	594N3202730E
M12 power cable	594B8120B30E
M12 USB cable	

*Specifications and certifications are based on options and may vary.

Expansion & Installation

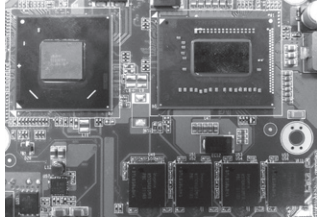

Onboard 3rd Gen. Intel® Core™ i7 or i3 processor and 4 GB or 2 GB DDR3-1600 DRAM



Swappable and lockable SATA3 HDD/SSD, audio jack, USB 3.0 & CFast™



M12 connector for power, Giga LAN, USB 2.0 & audio port

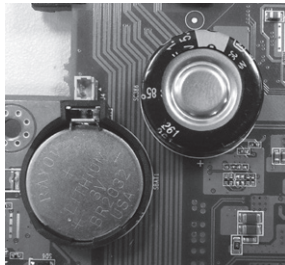

Both battery and wide temperature goldcap onboard

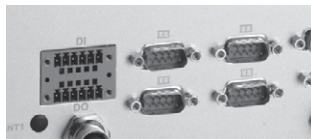

Isolated RS-232/422/485 & DIO



3 PCIe Mini Card slots with 1 SIM slot

Packing List

- 1 x quick manual
- 1 x driver CD
- 1 x screw pack
- 4 x foot pad
- 8 x HDD anti-vibration damper
- 1 x wall-mount kit

Power Protection

DC Version

- SCP (short circuit protection)
- OVP (over voltage protection)
- UVP (under voltage protection)

Dimensions

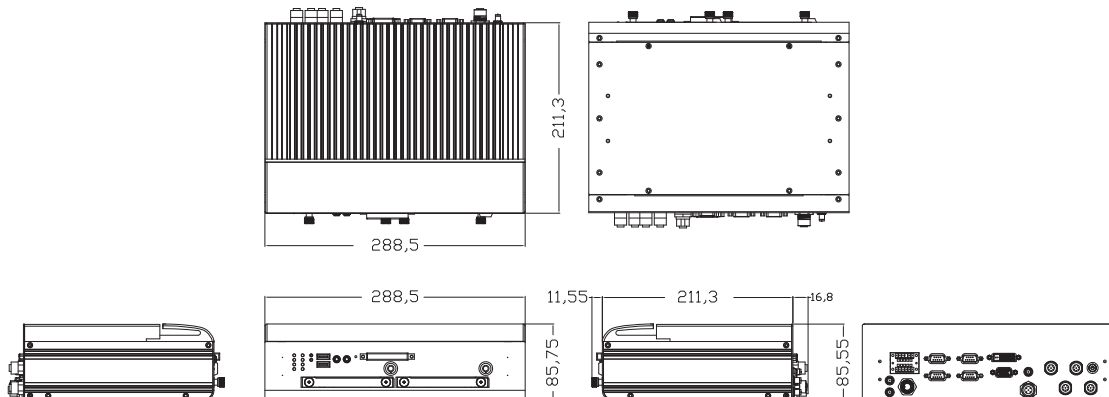

* All specifications and photos are subject to change without notice.
© 2013 Axiomtek Co., Ltd. All rights reserved.