

## Main Features

- Support 2nd generation Intel® Core™ Workstation processors
- 4x DDR3 DIMM Socket up to 32 GB, support ECC SDRAM
- VGA + DVI dual displays
- 2x Intel® Gigabit Ethernet
- Support Intel® AMT 7.0
- 1x PCIe x16 (with PCIe x8 signals), 1x PCIe x8, 2x PCIe x4 slots
- Support SATA 3.0, 2x RS232

## Product Overview

NEX 890 is an industrial motherboard with Micro ATX form factor, which Support 2nd generation Intel® Core™ Workstation processors with Hyper-Threading technology.

The 2nd generation Intel® Core™ Workstation processors support dual channel ECC DDR3 1066/1333 MHz memory in four DIMM slots and integrated HD graphics controller. The C206 PCH manages SATA 3.0 ports and USB 2.0 ports. Furthermore, it supports other versatile I/O ports such as two serial ports, ten USB ports, and two Intel PCI Express Gigabit LAN ports. It offers a great solution for advanced industrial application that requires superb display and processing performance.

## Specifications

### CPU Support

- LGA1155, 2nd generation Intel® Core™ Workstation processors

### Main Memory

- 4x 240-pin DIMM, for up to 32GB dual channel ECC DDR3 1066/1333 SDRAM

### Chipset

- Intel® C206 Platform Controller Hub

### BIOS

- AMI BIOS
- Plug and play support

### On-board LAN

- 1x Intel® 82579LM PHY for AMT 7.0
- 1x Intel® 82583 PCI Express Gigabit Ethernet
- Support boot from LAN (PXE)
- 2x RJ45 with LED

### Display

- 2nd generation Intel® Core™ Desktop processors Integrated HD graphics
- 1x VGA
- 1x DVI-D

### Expansion

- 1x PCIe x16 (with PCIe x8 signals) slot
- 1x PCIe x8 slot
- 2x PCIe x4 slots

### Edge I/O Interfaces

- 1x dual stack Mini DIN 6-pin connector for PS/2 KB/MS
- 1x dual stack DB9 male connector for COM1 & COM2
- 1x DVI + DB15 female connector VGA
- 2x RJ45 with dual stack USB connectors
- Line-In/ Line-Out/ MIC phone jack

### I/O Interface

- USB 2.0: 10 ports (6 on board pin header, 4 with type A connector for external)
- Serial port: 2 port, with 2x 5pin headers (COM 1 and COM 2)
- SATA HDD: 6 ports, port 1, 2 support SATA 3.0, port 3, 4, 5, 6 support SATA 2.0
- Support RAID 0/ 1/ 5/ 10 and Intel® Matrix Storage
- IrDA: on board pin header
- GPIO: Supports 4 sets general purpose I/O each with TTL level (5 V) interface
- On-board buzzer x1
- Power LED/ Power On/ Reset/ HDD LED pin header
- 1x 4-pin fan connector (for CPU); 2x 3-pin fan connectors (for System)

## Block Diagram

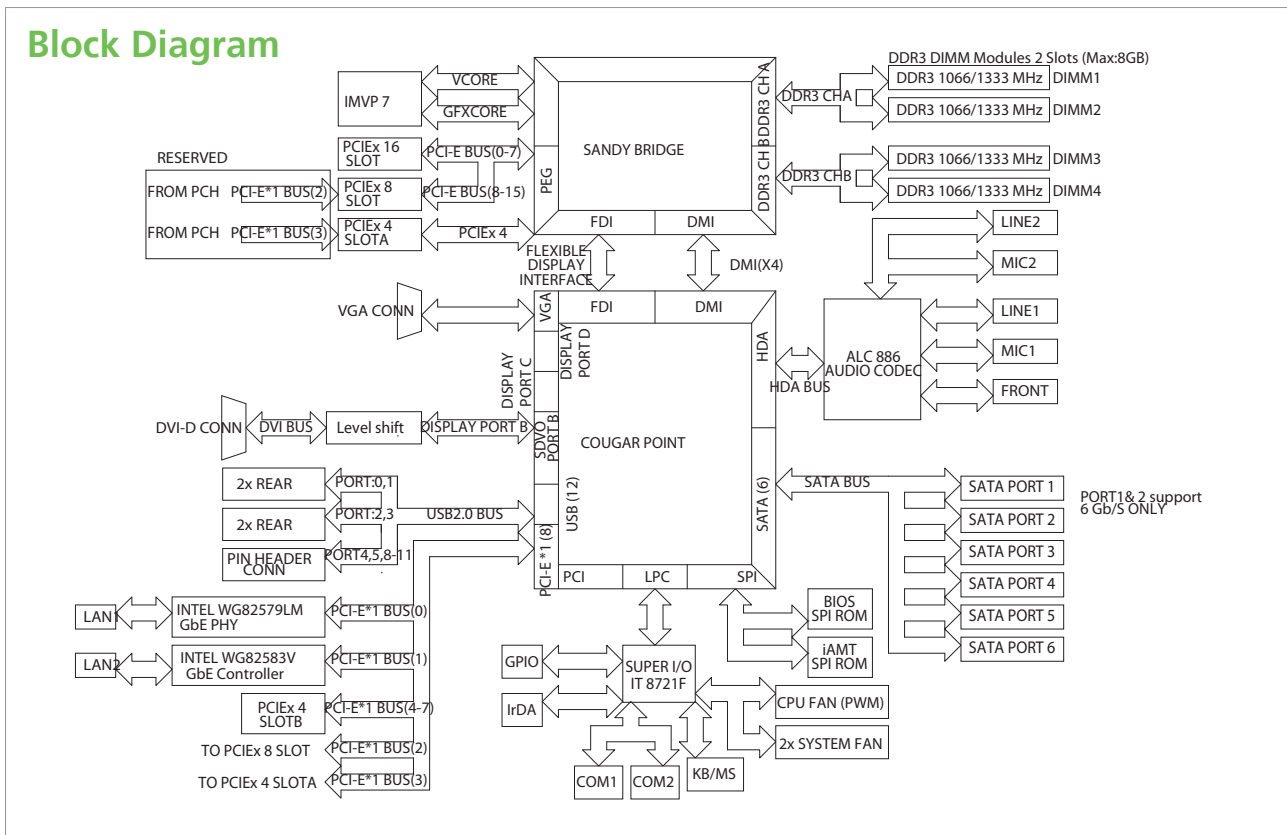

- On-chip RTC with battery backup
- 1x External Li-Ion battery

### System Monitor

- 4 Voltages (+3.3V, +5V, +12V, Vcore)
- 2 Temperatures (For CPU and System)
- 3 FAN speed monitors (1 for CPU and 2 for System FAN)

### Power Input

- Support ATX power supplies
- Standard ATX 24-pin connector for +12V/ +5V/ +3.3V/ +5Vsb/ -12V
- ATX 8-pin connector for +12V

### Dimensions

- Micro ATX
- Dimension: 244mm (L) x 244mm (W)

### Environment

- Board level operating temperatures: 0°C to 60°C
- Storage temperature: -20°C to 85°C
- Relative humidity: 10% to 90%, (Non-condensing)

### Certifications

- CE approval
- FCC Class A

## Ordering Information

### • NEX 890 (P/N : 10G00089000X0)

Micro ATX, LGA1155, 2nd generation Intel® Core™ Workstation processors, C206, DDR3 DIMM x4, VGA, DVI-D, 2x GbE, PCIe x8/ PCIe x4/ 2 x PCIe x1, 2x RS232