



EIZO®

28.1" Primary Control Monitor

Raptor® SQ2825



## Design

### Slim Bezels

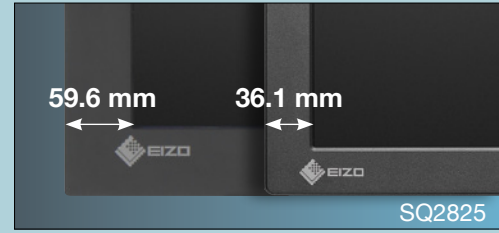

The unobtrusive bezels are approximately 40% slimmer than the previous model, measuring just 36.1 mm on all sides so ATCOs can focus more on the screen.

### Protection Glass

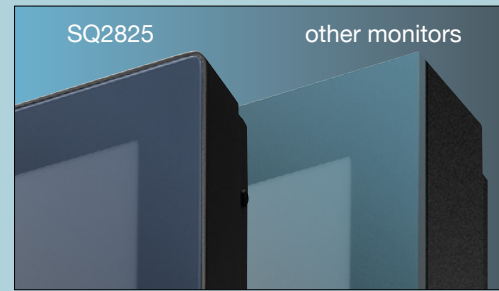

Protection glass is optional with two variations — standard and fully flat. Standard glass covers the visible part of the LCD panel and extends to the inner bezel. Fully flat glass reaches to the edges of the monitor for a smooth, streamlined look. The monitor's housing is built with edge protection for fully flat glass so it is not exposed and vulnerable to damage.

### Rounded Corners



The monitor's design features rounded corners and edges for a pleasing and modern aesthetic.

### Balanced Design

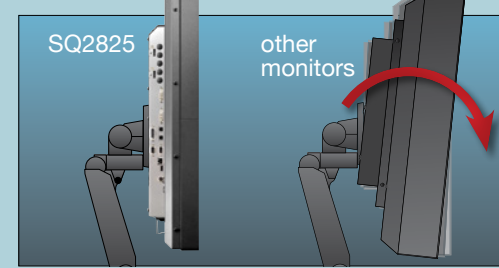

The monitor's depth has been reduced, bringing the weight distribution closer to the center of mass for less stress on mounting fixtures over time. It is also 50% lighter and more compact than the previous model, weighing just 14.6 kg.

### Brightness Uniformity

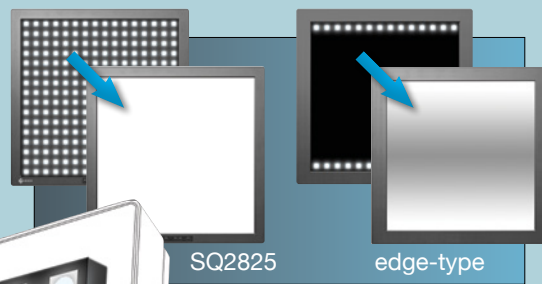

The monitor's unique LED direct backlight system has 16% more LED cells than its predecessor for increased efficiency and performance. It offers superior brightness uniformity for smoother images compared to edge-type backlight solutions.

### Mission-Critical Redundancy

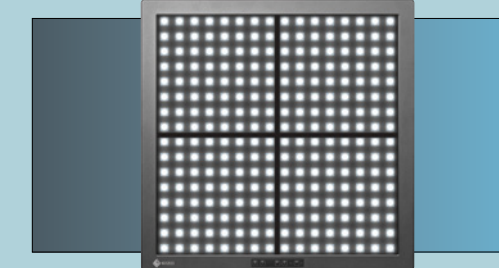

The direct backlight system is divided into four interchangeable quadrants, each of which performs consistently over a lifetime of 100,000 hours. Each quadrant is controlled by two independent sub-unit driver boards that protect the on-screen information from being visually impacted in the unlikely event that an LED stops performing.

### Wide Brightness Range



The monitor can be adjusted within a wide brightness range of 2 to 500 cd/m<sup>2</sup> to suit your environment's requirements as well as the needs of the ATCO.

### Brightness Stabilization

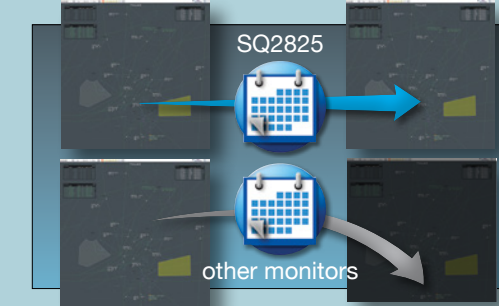

EIZO's fully automated stability function uses an internal backlight sensor to stabilize the brightness level throughout the life of the monitor, compensating for fluctuations caused by variations in ambient temperature and the passage of time.

### Energy Efficiency



The monitor consumes just 120 watts at maximum brightness (500 cd/m<sup>2</sup>) and even less under typical control room operating conditions. This saves energy and significantly reduces heat generation within the monitor; a leading cause of component failure.

### Mounting Flexibility

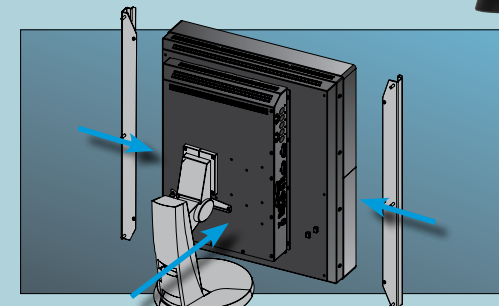

The newly designed rear housing can be easily configured to any mounting requirements without needing to remove any part of the housing. This ensures flexibility for meeting new installations or hardware changes that require desktop, VESA, chassis, panel mount or any combination thereof.

### Energy Efficiency

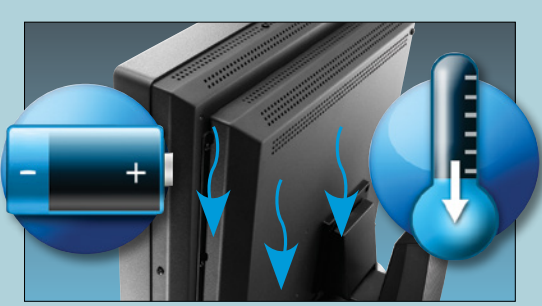

The monitor consumes just 120 watts at maximum brightness (500 cd/m<sup>2</sup>) and even less under typical control room operating conditions. This saves energy and significantly reduces heat generation within the monitor; a leading cause of component failure.

## Durability and Reliability

### Industrial-Grade Housing



The monitor's housing uses full sheet steel industrial-grade housing for durability in demanding mission-critical environments.

### Fanless Operation

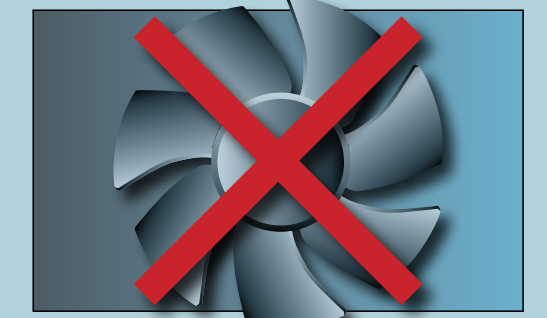

The monitor provides noiseless, fanless operation while still maintaining low heat output without impacting performance.

### Built-In Power Supply



The power supply of the monitor is built in, freeing the installation space of an additional power brick and cabling. A secondary power supply is available as an option.

### 24/7 Operation

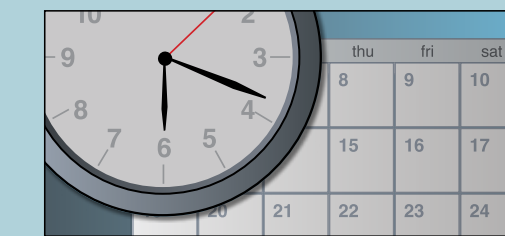

The Raptor SQ2825 is developed specifically for meeting the stringent requirements of mission-critical ATC environments with 24/7 operation.

# 10+ Years of Primary Control Monitor Manufacturing

EIZO has been an industry leader in the innovation and development of quality 2K primary control monitors for ATC since 2005. Backed by over 45 years of technical expertise in visual display solutions, the Raptor SQ2825 is a 5th generation 2K x 2K monitor that culminates the features and functionality of EIZO's line of primary control monitors while adding further value with new technology and improved operational reliability.

## Extensive Customization

EIZO offers extensive customization in order to meet the specific needs of individual control centers.

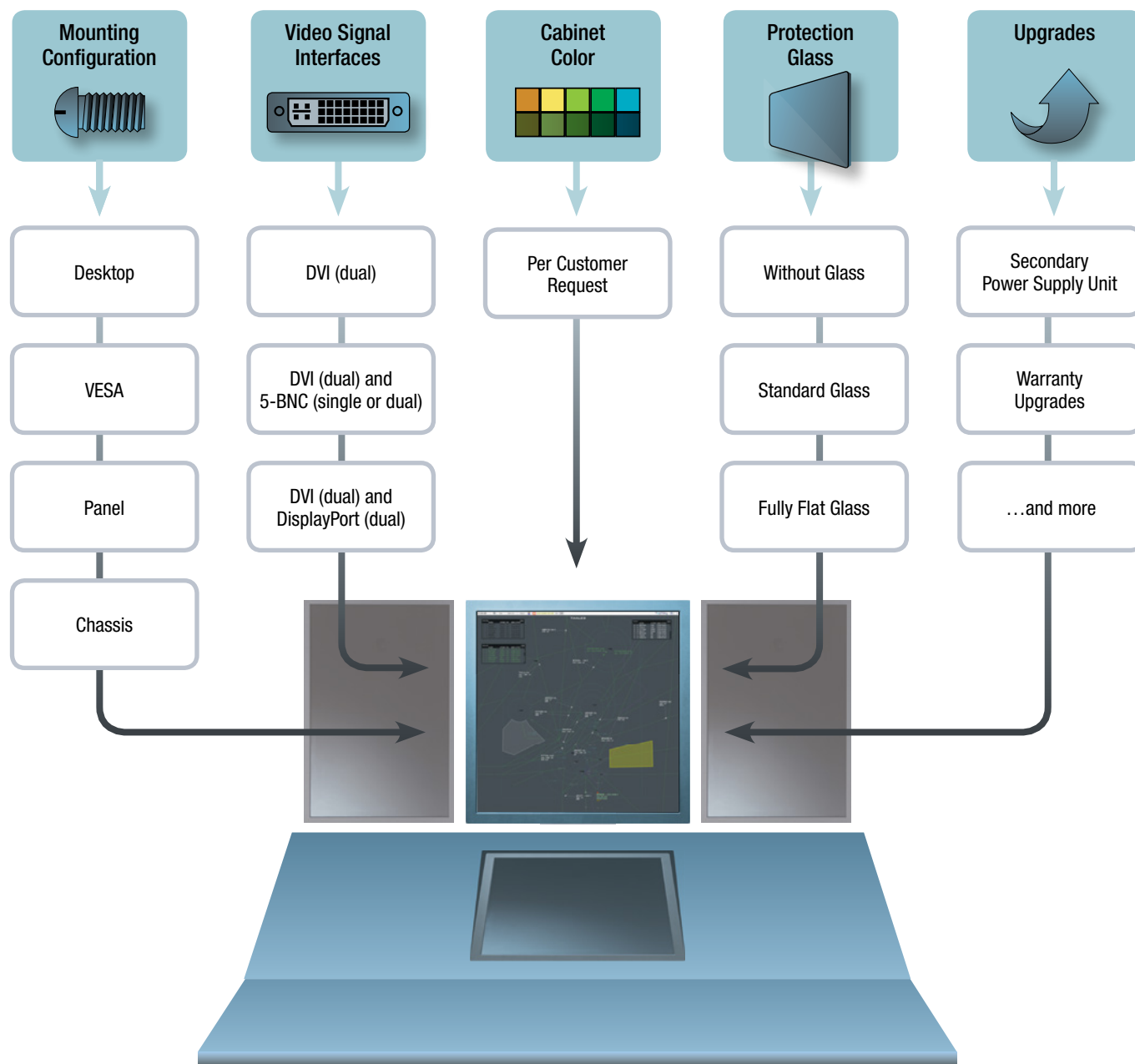

Contact us to configure your monitor.  
[atc@eizo.com](mailto:atc@eizo.com)

### Complete Connection

Dual link DVI video signal inputs are included as standard as well as the option of additional DisplayPort or analog 5-BNC inputs. The monitor also comes equipped with a wide range of communication interfaces for connection to a network, remote monitor management, or maintenance purposes — RS232, RS422, USB, and TCP/IP.

### Non-Intrusive Hardware Calibration

The monitor comes equipped with EIZO's hardware calibration functionality using the optional EIZO EACAL-R01 luminance reader. Easily accessed through the OSD menu, calibration of the backlight brightness, gamma, and white point can be carried out in just minutes. No additional software is needed, ensuring calibration operation is non-intrusive to your system.

### Optional Accessories

#### EACAL-R01

External advanced serial luminance meter for high-precision monitor calibration.



#### EACON-S01

External OSD keyboard for control of a single monitor.



### Specifications

Cabinet Color		Black	
Panel	Type	VA	
	Backlight	Direct LED backlight system	
	Size	28.05" / 71.2 cm	
	Native Resolution	2048 x 2048 (1:1 aspect ratio)	
	Viewable Image Size (H x V)	503.8 x 503.8 mm	
	Pixel Pitch	0.246 x 0.246 mm	
	Grayscale Tones	256 tones	
	Display Colors	16.7 million	
	Viewing Angles (H / V, typical)	170°, 170°	
	Brightness (typical)	500 cd/m <sup>2</sup> (maximum) 2 cd/m <sup>2</sup> (minimum)	
Contrast Ratio (typical)	1800:1		
Response Time (typical)	25 ms		
Video Signals	Input Terminals	DVI-I 29 pin (dual-link) x 2 5-BNC (single or dual, optional) or DisplayPort (dual, optional)	
	Digital Scanning Frequency (H / V)	2 – 130 MHz (pixel) / 60 Hz	
	Analog Scanning Frequency (H / V)	30 – 130 kHz / 50 – 70 Hz	
	Sync Formats	Separate Sync 1-5 Vpp (75 Ω) / Sync on Green	
USB	Function	2 upstream	
	Standard	Rev. 2.0	
Power	Power Requirements	AC 90 – 264 V, 47 – 63 Hz	
	Maximum Power Consumption	120 W (Brightness: 500 cd/m <sup>2</sup> )	
	Typical Power Consumption	60 W (Brightness: 150 cd/m <sup>2</sup> ) 50 W (Brightness: 70 cd/m <sup>2</sup> )	
	Standby Mode	0.5 W or less	
	Power Management	VESA DPMS	
Features and Functions	Brightness Stabilization	Yes	
	OSD Languages	English, German, Spanish, French	
	Hardware Calibration	Yes (Requires luminance meter: EACAL-R01)	
	External Keyboard	Yes (Requires hardware keyboard: EACON-S01 or EACON-S02)	
	Preset Modes	Factory, User1	
	Communication Protocol	Sony DDM, standard, simplified, SNMP	
Physical Specifications	Communication Interface	RS232-1 / RS232-2, RS422, USB-1 / USB-2, TCP/IP	
	Dimensions (With Stand, W x H x D)	576 x 603 – 688.4 x 280.6 mm	
	Dimensions (VESA Mount, W x H x D)	576 x 576 x 119 mm	
	Dimensions (Chassis Mount, W x H x D)	603 x 639 x 119 mm	
	Net Weight (With Stand, W x H x D)	18.6 kg / 41 lbs	
	Net Weight (VESA Mount, W x H x D)	14.6 kg / 32.2 lbs	
	Net Weight (Chassis Mount, W x H x D)	15.1 kg / 33.3 lbs	
	Height Adjustment Range	85 mm	
	Tilt	25° Up, 0° Down	
	Swivel	172° Right, 172° Left	
	Hole Spacing (VESA Standard)	100 x 100 mm, 200 x 100 mm	
	Environmental Requirements	Operating Temperature	0 – 40°C / 32 – 104°F
		Operating Humidity (R.H., non condensing)	max. 95% (no condensation)
Storage Temperature		-25 – 60°C / -13 – 140°F	
Certifications & Standards	CE, UL, c-UL, FCC, RoHS, WEEE, CCC		
Warranty	Two Years		

### EIZO Technologies GmbH

Bürgermeister-Seidl-Str. 8, 82515 Wolfrahausen, Germany  
 Phone : +49-8171-3492-11 Fax : +49-8171-3492-16  
[atc@eizo.com](mailto:atc@eizo.com)  
[www.eizoglobal.com](http://www.eizoglobal.com)

All product names and logos are trademarks or registered trademarks of their respective companies. Raptor and EIZO are registered trademarks of EIZO Corporation. Screen images provided by THALES. Specifications are subject to change without notice.

Copyright © 2018 EIZO Corporation. All rights reserved.  
 Printed in Japan, 2, 2018, 0.5K (160806c)