



10623 Roselle Street, San Diego, CA 92121 • (858) 550-9559 • Fax (858) 550-7322  
contactus@accessio.com • www.accessio.com

**DAQ-PACK M SERIES  
MULTI-CHANNEL  
HIGH-SPEED  
ANALOG I/O FAMILY  
USER GUIDE**

## **Notice**

The information in this document is provided for reference only. ACCES does not assume any liability arising out of the application or use of the information or products described herein. This document may contain or reference information and products protected by copyrights or patents and does not convey any license under the patent rights of ACCES, nor the rights of others. IBM PC, PC/XT, and PC/AT are registered trademarks of the International Business Machines Corporation. Copyright by ACCES I/O Products, Inc. 10623 Roselle Street, San Diego, CA 92121. All rights reserved.

## **WARNING!!**

**ALWAYS CONNECT AND DISCONNECT YOUR FIELD CABLING WITH THE COMPUTER POWER OFF. ALWAYS TURN POWER OFF BEFORE CONNECTING AND DISCONNECTING CABLES, FAILURE TO DO SO MAY CAUSE DAMAGE TO THE DAQ-PACK AND WILL VOID ALL WARRANTIES, IMPLIED OR EXPRESSED.**

## **CAUTION!!**

**THE DAQ-PACK SERIES IS A FULLY FACTORY CONFIGURED AND INTEGRATED INSTRUMENT, DO NOT OPEN THE ENCLOSURE, DOING SO WILL VOID YOUR WARRANTY**

## **Warranty**

Prior to shipment, ACCES equipment is thoroughly inspected and tested to applicable specifications. However, should equipment failure occur, ACCES assures its customers that prompt service and support will be available. All equipment originally manufactured by ACCES which is found to be defective will be repaired or replaced subject to the following considerations.

### **Terms and Conditions**

If a unit is suspected of failure, contact ACCES' Customer Service department. Be prepared to give the unit model number, serial number, and a description of the failure symptom(s). We may suggest some simple tests to confirm the failure. We will assign a Return Material Authorization (RMA) number which must appear on the outer label of the return package. All units/components should be properly packed for handling and returned with freight prepaid to the ACCES designated Service Center, and will be returned to the customer's/user's site freight prepaid and invoiced.

### **Coverage**

First Three Years: Returned unit/part will be repaired and/or replaced at ACCES option with no charge for labor or parts not excluded by warranty. Warranty commences with equipment shipment. Following Years: Throughout your equipment's lifetime, ACCES stands ready to provide on-site or in-plant service at reasonable rates similar to those of other manufacturers in the industry.

### **Equipment Not Manufactured by ACCES**

Equipment provided but not manufactured by ACCES is warranted and will be repaired according to the terms and conditions of the respective equipment manufacturer's warranty.

### **General**

Under this Warranty, liability of ACCES is limited to replacing, repairing or issuing credit (at ACCES discretion) for any products which are proved to be defective during the warranty period. In no case is ACCES liable for consequential or special damage arriving from use or misuse of our product. The customer is responsible for all charges caused by modifications or additions to ACCES equipment not approved in writing by ACCES or, if in ACCES opinion the equipment has been subjected to abnormal use. "Abnormal use" for purposes of this warranty is defined as any use to which the equipment is exposed other than that use specified or intended as evidenced by purchase or sales representation. Other than the above, no other warranty, expressed or implied, shall apply to any and all such equipment furnished or sold by ACCES.

## TABLE OF CONTENTS

Chapter 1: Introduction and Installation .....	4
Included with your DAQ-PACK M Series Module .....	4
Optional Mounting Accessories .....	4
Figure 1-1: Block Diagram .....	5
Chapter 2: Mechanical Drawings .....	6
Figure 2-1: DAQ-PACK M Series Enclosure .....	6
Figure 2-2: DAQ-PACK Mounting Provisions .....	6
Figure 2-3: DPK-DIN-CLIP .....	7
Figure 2-4: DPK-MOUNT .....	7
Chapter 3: USB Address Information .....	8
Table 3-1: Product ID to Model Number .....	8
Chapter 4: Programming .....	9
Chapter 5: Connector Pin Assignments .....	10
Table 5-1: J1 Connector Pin Assignments (DB37F) .....	10
Table 5-2: J2 Connector Pin Assignments (DB37F) .....	11
Table 5-3: J1 and J2 Signal Names and Descriptions .....	11
Table 5-4: J3 Connector Pin Assignments (DB25F) .....	12
Table 5-5: J3 Signal Names and Descriptions .....	12
Chapter 6: Primary Specifications .....	13
Customer Comments .....	14

## Chapter 1: Introduction and Installation

This guide describes the DAQ-PACK M Series of Enclosed Multi-function Data Acquisition Models. These are fully factory configured and integrated into a rugged steel enclosure.

This guide provides all of the information most users will need. For full technical details and specifications, refer to the following comprehensive manuals:

- [USB-AIO Series.PDF](#) USB Multi-Channel High-Speed Analog I/O Family Models USB-AIO16-xxx and USB-AIO12-xxx
- [USB Software Reference.pdf](#) USB Software Reference Manual

As the DAQ-PACK M Series is factory integrated into the enclosure, there should be no need for users to open the box. Doing so may void your warranty. For technical assistance, please contact us toll-free at 800-326-1649 and a technician will be happy to help you.

### Included with your DAQ-PACK M Series Module

The following components are included with your shipment depending on model and options ordered. Please take time now to ensure that no items are damaged or missing.

- DAQ-PACK M Series Module installed in an enclosure with an anti-skid bottom
- 6' USB 2.0 Type A to B cable
- Software Master CD (PDF reference manuals installed with product package)
- Printed DAQ-PACK Series User Guide

### Optional Mounting Accessories

Drawings of these accessories are in Chapter 2 of this guide.

DPK-DIN-CLIP	DIN rail mounting clip w/3 x 8/32 FHP 3/8" SS screws
DPK-MOUNT	Panel mounting plate w/3 x 8/32 FHP 3/8" SS screws

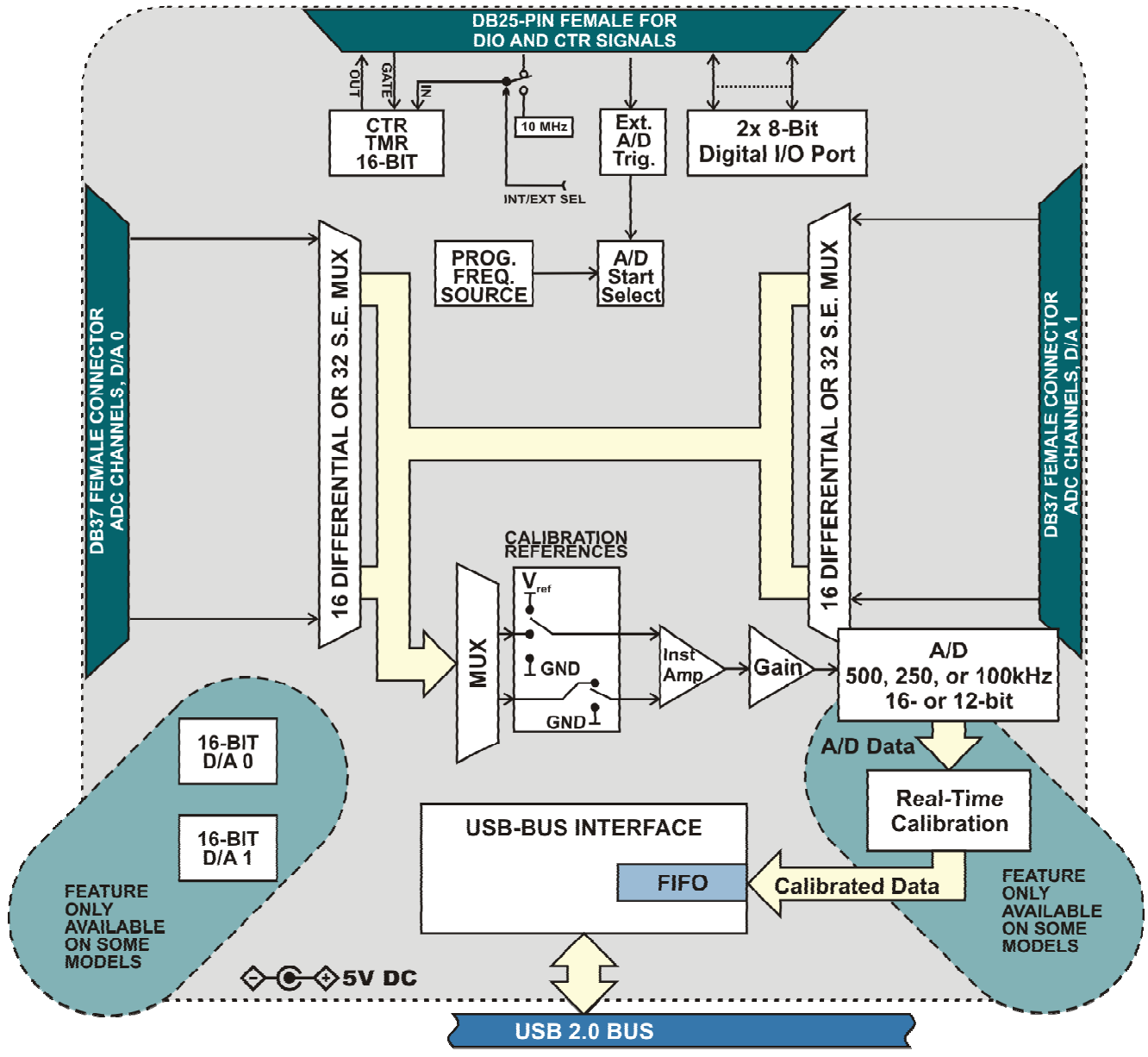

Figure 1-1: Block Diagram

# Chapter 2: Mechanical Drawings

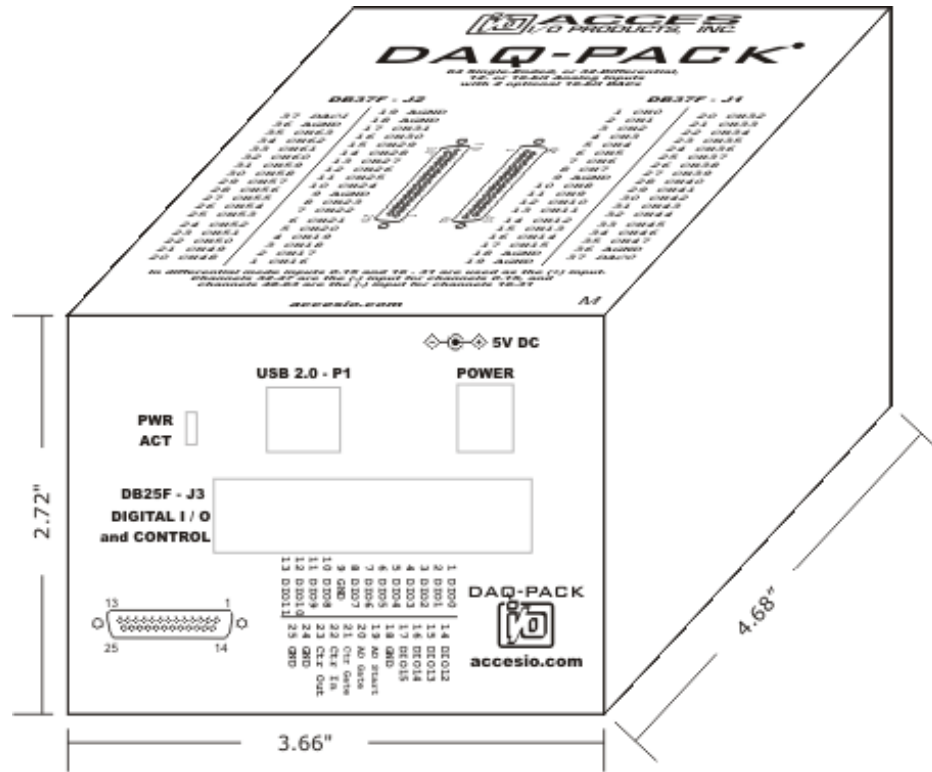

Figure 2-1: DAQ-PACK M Series Enclosure

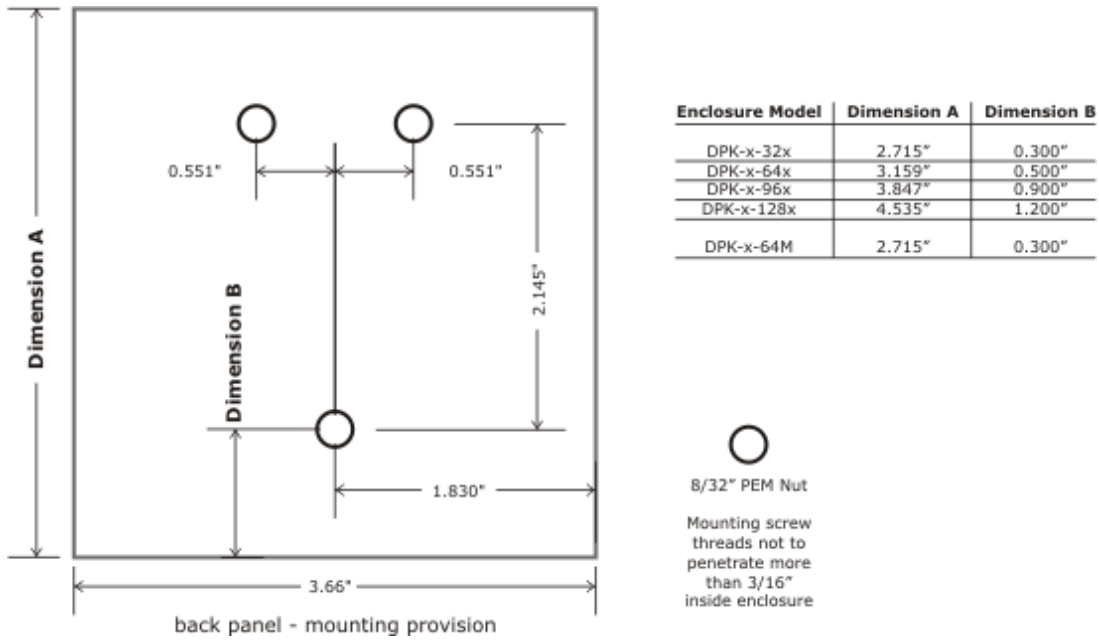
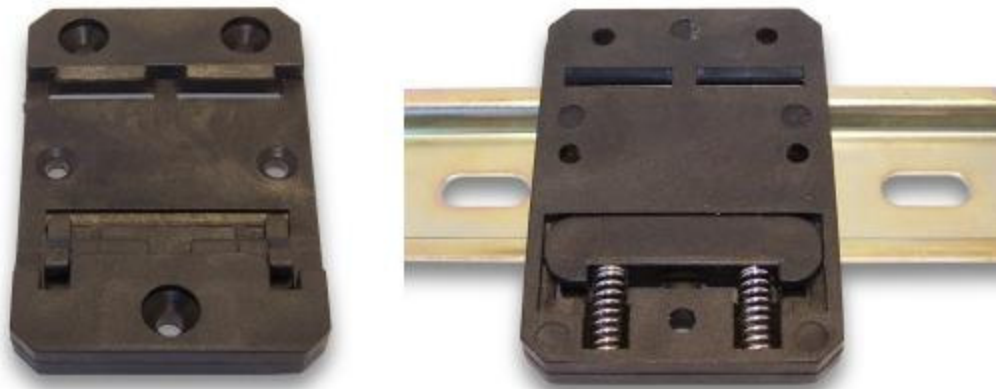
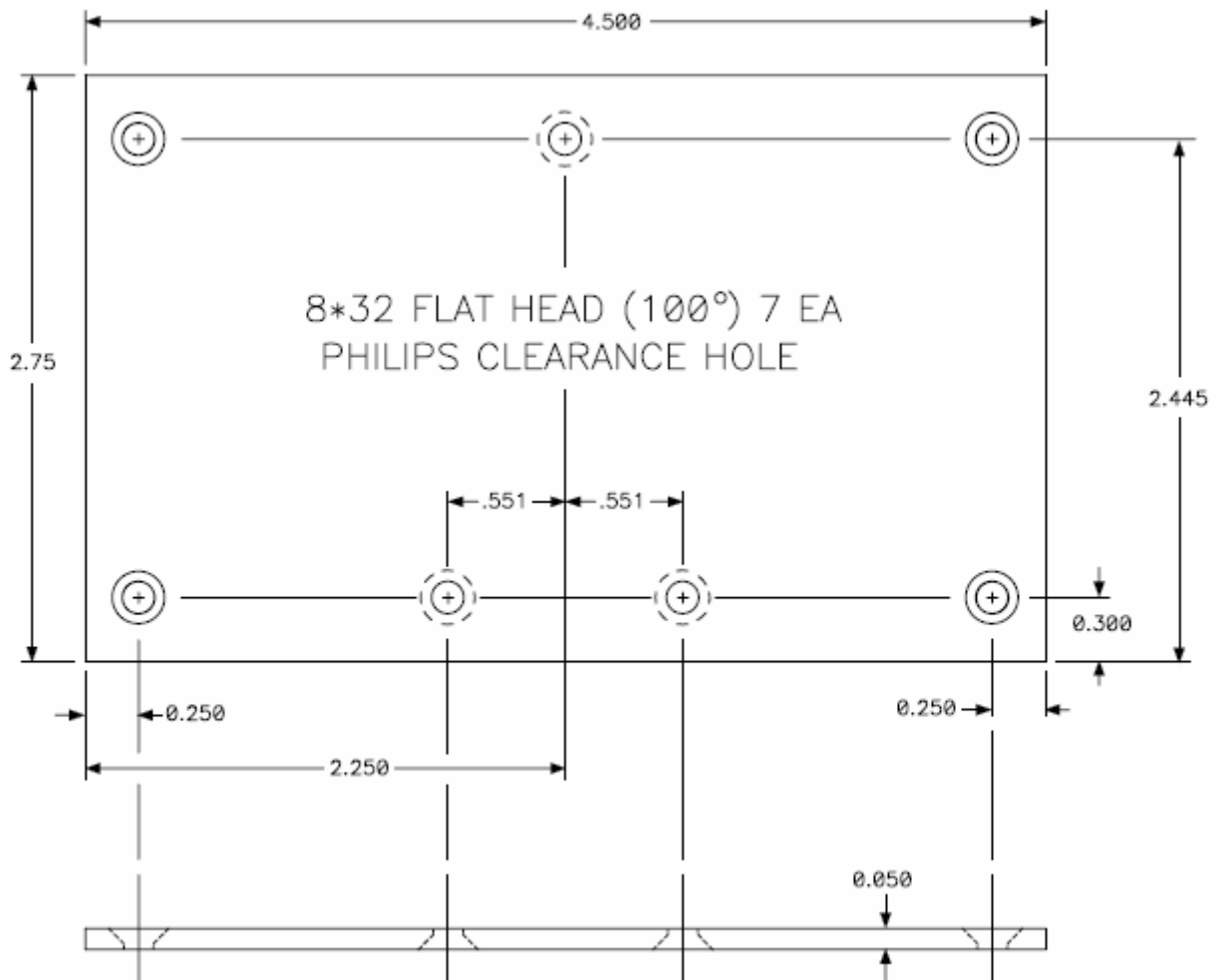

Figure 2-2: DAQ-PACK Mounting Provisions



**Figure 2-3: DPK-DIN-CLIP**



**Figure 2-4: DPK-MOUNT**

## Chapter 3: USB Address Information

Use the provided driver to access the DAQ-PACK M Series. This driver will allow you to determine how many supported USB devices are currently installed, and each device's type. This information is returned as a Vendor ID (VID), Product ID (PID) and Device Index.

The VID is "0x1605" and the PID is listed in the following table.

8045	USB-AI16-64MA	8145	USB-AIO16-64MA
8046	USB-AI16-64ME	8146	USB-AIO16-64ME
8047	USB-AI12-64MA	8147	USB-AIO12-64MA
8048	USB-AI12-64M	8148	USB-AIO12-64M
8049	USB-AI12-64ME	8149	USB-AIO12-64ME

**Table 3-1: Product ID to Model Number**



## Chapter 4: Programming

The driver software provided with the board uses a 32-bit .dll front end compatible with any Windows programming language. Samples provided in Borland C++Builder, Borland Delphi, Microsoft Visual Basic, and Microsoft Visual C++ demonstrate the use of the driver.

The easiest way to begin taking analog input data is using the following API call, but often can't achieve more than several hundred Hz, slower depending on options.

unsigned long **ADC\_GetScanV**( - This simple function takes one scan of A/D data and converts it to voltage. It also averages oversamples for each channel. The array must contain one entry per A/D channel on the board, though only entries [start channel] through [end channel] are altered. On boards with A/D that don't support **ADC\_SetConfig()**, it scans all channels, without oversampling.

unsigned long DeviceIndex - number from 0-31 indicating from which device you wish to get a scan of data

double \*pBuf - a pointer to the first of an array of double precision IEEE floating point numbers which will each receive the value read from one channel

)

For full programming details see the USB Software Reference Manual installed on your system along with the product software package.

## Chapter 5: Connector Pin Assignments

The DAQ-PACK M Series is available in five basic flavors, always consisting of the USB interface and A/D board and one AIMUX-64 multiplexer board. The A/D board may also have two 16-bit analog outputs (specify at time of ordering). Signals present on these connectors are as follows:

### Connectors

P1	USB Type B	High Retention Connector for reliable USB Interface
J1	DB37 Female	Ch 0-15 differential & S.E. Ch 32-47 S.E. analog inputs and temp sensor
J2	DB37 Female	Ch 16-31 differential & S.E. Ch 48-63 S.E. analog inputs
J3	DB25 Female	A/D control and digital I/O
DC POWER		Optional External Regulated 5V Power Input

Pin	Signal Name	Pin	Signal Name
1	CH0(SE) / CH0+(DIFF)	20	CH32(SE) / CH0-(DIFF)
2	CH1(SE) / CH1+(DIFF)	21	CH33(SE) / CH1-(DIFF)
3	CH2(SE) / CH2+(DIFF)	22	CH34(SE) / CH2-(DIFF)
4	CH3(SE) / CH3+(DIFF)	23	CH35(SE) / CH3-(DIFF)
5	CH4(SE) / CH4+(DIFF)	24	CH36(SE) / CH4-(DIFF)
6	CH5(SE) / CH5+(DIFF)	25	CH37(SE) / CH5-(DIFF)
7	CH6(SE) / CH6+(DIFF)	26	CH38(SE) / CH6-(DIFF)
8	CH7(SE) / CH7+(DIFF)	27	CH39(SE) / CH7-(DIFF)
9	AGND	28	CH40(SE) / CH8-(DIFF)
10	CH8(SE) / CH8+(DIFF)	29	CH41(SE) / CH9-(DIFF)
11	CH9(SE) / CH9+(DIFF)	30	CH42(SE) / CH10-(DIFF)
12	CH10(SE) / CH10+(DIFF)	31	CH43(SE) / CH11-(DIFF)
13	CH11(SE) / CH11+(DIFF)	32	CH44(SE) / CH12-(DIFF)
14	CH12(SE) / CH12+(DIFF)	33	CH45(SE) / CH13-(DIFF)
15	CH13(SE) / CH13+(DIFF)	34	CH46(SE) / CH14-(DIFF)
16	CH14(SE) / CH14+(DIFF)	35	CH47(SE) / CH15-(DIFF)
17	CH15(SE) / CH15+(DIFF) / LM335+ term.	36	AGND
18	AGND / LM335- terminal	37	AGND(AI) / DAC0 (AIO)
19	AGND		

**Table 5-1: J1 Connector Pin Assignments (DB37F)**

Pin	Signal Name	Pin	Signal Name
1	CH16(SE) / CH16+(DIFF)	20	CH48(SE) / CH16-(DIFF)
2	CH17(SE) / CH17+(DIFF)	21	CH49(SE) / CH17-(DIFF)
3	CH18(SE) / CH18+(DIFF)	22	CH50(SE) / CH18-(DIFF)
4	CH19(SE) / CH19+(DIFF)	23	CH51(SE) / CH19-(DIFF)
5	CH20(SE) / CH20+(DIFF)	24	CH52(SE) / CH20-(DIFF)
6	CH21(SE) / CH21+(DIFF)	25	CH53(SE) / CH21-(DIFF)
7	CH22(SE) / CH22+(DIFF)	26	CH54(SE) / CH22-(DIFF)
8	CH23(SE) / CH23+(DIFF)	27	CH55(SE) / CH23-(DIFF)
9	AGND	28	CH56(SE) / CH24-(DIFF)
10	CH24(SE) / CH24+(DIFF)	29	CH57(SE) / CH25-(DIFF)
11	CH25(SE) / CH25+(DIFF)	30	CH58(SE) / CH26-(DIFF)
12	CH26(SE) / CH26+(DIFF)	31	CH59(SE) / CH27-(DIFF)
13	CH27(SE) / CH27+(DIFF)	32	CH60(SE) / CH28-(DIFF)
14	CH28(SE) / CH28+(DIFF)	33	CH61(SE) / CH29-(DIFF)
15	CH29(SE) / CH29+(DIFF)	34	CH62(SE) / CH30-(DIFF)
16	CH30(SE) / CH30+(DIFF)	35	CH63(SE) / CH31-(DIFF)
17	CH31(SE) / CH31+(DIFF) / LM335 + terminal	36	AGND
18	AGND / LM335 – terminal	37	AGND (AI) / DAC1(AIO)
19	AGND		

**Table 5-2: J2 Connector Pin Assignments (DB37F)**

Signal Name	I/O	Description
Ch0 thru Ch31(SE)/Ch0+ thru Ch31+ (DIFF)	I	Channel 0 thru Channel 31 single-ended or Channel 0 thru Channel 31 differential non-inverting input
Ch32 thru Ch63(SE)/Ch0- thru Ch31- (DIFF)	I	Channel 32 thru Channel 63 single-ended or Channel 0 thru Channel 31 differential inverting input
LM335 + terminal	I	Temperature sensor + lead for reference junction or cold-junction compensation. When this option is ordered, Channel 1 is factory configured to provide a + bias to a provided LM335 precision temperature sensor, which should be connected to the also provided screw terminal adapter model UTBK-50.
LM335 - terminal	I	When this option is ordered, connect the – lead of the provided LM335 precision temperature sensor to the also provided screw terminal adapter model UTBK-50.
AGND	x	Analog Ground, All single-ended <i>AND</i> differential signals must have a ground reference connected on one of these pins.
TEMP+ (LM335) (CH8+)	I	Temperature sensor input circuit (LM335 + lead) when TEMP1 jumper is installed. Connected to channel 8 differential non-inverting input
DAC0 / DAC1	O	Digital to Analog Output 0 / 1
AGND / DAC0 / DAC1 return	x	DAC0 or 1's ground when installed. Otherwise, Analog Ground

**Table 5-3: J1 and J2 Signal Names and Descriptions**

Pin	Signal Name	Pin	Signal Name
1	DIO0	14	DIO12
2	DIO1	15	DIO13
3	DIO2	16	DIO14
4	DIO3	17	DIO15
5	DIO4	18	GND
6	DIO5	19	External Trigger
7	DIO6	20	A/D Start Enable
8	DIO7	21	Counter Gate
9	GND	22	Counter Clock
10	DIO8	23	Counter Output
11	DIO9	24	GND
12	DIO10	25	GND
13	DIO11		

**Table 5-4: J3 Connector Pin Assignments (DB25F)**

Signal Name	I/O	Description
DIO0 – DIO15	I/O	Digital Input and Digital Output lines (SW configurable, pulled-up)
AGND	x	Analog Ground
GND	x	Ground (power and digital signaling)
Counter Gate	I	External A/D Enable / Counter Gate Input (pulled-up, active-high)
External Trigger	I	Ext A/D Conversion Start Trigger (pulled-up, SW selectable for rising or falling edge)
A/D Start Enable	I	External A/D Conversion Start Enable (pulled-up, active-high)
Counter Clock	I	8254 Counter/Timer Clock Input (pulled-up)
Counter Output	O	8254 Counter/Timer Output (pulled-up)

**Table 5-5: J3 Signal Names and Descriptions**

## Chapter 6: Primary Specifications

### PRIMARY SPECIFICATIONS (full specs in USB-AIO Series manual)

<b>Analog Inputs</b>	Successive approximation
Resolution	16-bit or 12-bit
Sampling rate	100k - 500ksps, depending on model
Channels	32 differential, or 64 single ended inputs
Uni, Bipolar( $\pm$ ) ranges	100mV, 200mV, 400mV, 500mV, 1V, 2V, 2.5V, 5V, 10V Uni-, bipolar ranges of 1mV, 5mV, 10mV, 20mV, 50mV
Calibration Hardware	
"16-, 12-A" versions	Two on-board ref's + calibrated real-time output
"16-E" version	Two on-board references
"12-xxx" version	Two on-board references
"12-xxxE" version	None
System Calibration	Program provided to calibrate entire system
Accuracy	Uncalibrated           0.094% Full-Scale (FS) Calibrated <sup>(1)</sup> 0.0015% FS
Input impedance	1M $\Omega$
A/D Start Sources	Software, Timer, External Start Trigger

<sup>(1)</sup> For best accuracy, one must calibrate to their own standard.

<b>Analog Outputs</b>	2
Type / Resolution	Single-ended, 16-bit
Uni, Bipolar( $\pm$ ) Ranges	5V, 10V (factory installed)
Conv. / Settling	4kHz / 4us typ, 7us max; $\frac{1}{4}$ - $\frac{3}{4}$ scale to $\pm 2$ LSBs
Drive Current	$\pm 25$ mA per channel

<b>Digital I/O</b>	16 inputs or outputs in groups of 8 (pulled-up)
Input volts/current	Logic low:           0V(min) to 0.8V(max) $\pm 20$ $\mu$ A Logic high:           2V(min) to 5V(max) $\pm 20$ $\mu$ A
Output volts/current	Logic low:           0V(min) to 0.55V(max) 64mA sink Logic high:           2V(min) to 5V(max) 32mA source

<b>Counter/Timer</b>	82C54 programmable interval counter
Available Counters	CTR0 (CTR1, CTR2 dedicated to A/D starts)
Input Frequency	10MHz (max)
Counter size	16-bit
Clock	Internal 10MHz or Externally supplied

<b>Environmental</b>	
Operating Temp.	0° to +70°C, optional -40° to +85°C
Storage Temp.	-40° to +105°C
Humidity	5% to 90% RH, without condensation

<b>Enclosure Dimensions</b>	(L x W x H) in inches
-64	4.680 x 3.660 x 2.720

<b>Power Required</b>	+5V at 320mA
-----------------------	--------------

## Customer Comments

If you experience any problems with this manual or just want to give us some feedback, please email us at: ***manuals@accessio.com***. Please detail any errors you find and include your mailing address so that we can send you any manual updates.



10623 Roselle Street, San Diego CA 92121

Tel. (858)550-9559 FAX (858)550-7322

[www.accessio.com](http://www.accessio.com)