

Features



- SUS 316 Stainless Steel
- Total IP66 Grade with M12 Waterproof Connector
- Wide range DC 9~36V Power Input
- Support Panel Mount & VESA Mount
- Support Projected Capacitive Touch
- Full Flat Bezel and Fanless Design
- Stainless Steel OSD Function Key
- ATEX Zone2, IECEx and C1D2 Certified
 - IECEX Certification: Ex nA ic IIC T4 Gc
 - ATEX Certification: Ex II 3 G
 - C1D2 Certification: Class I, Division 2, Groups A, B, C, D T4

Specifications

| External I/O | |
|-----------------|---|
| USB | 1 x M12 8-pin for 2 x USB 2.0 for Touch Control with waterproof cover and chain |
| Graph | 1 x M12 12-pin for VGA with waterproof cover and chain |
| Function Keypad | 1 x M12 8-pin for OSD Cable & External OSD BOX with waterproof cover and chain |
| Power | 1 x M12 3-pin for DC power connector with waterproof cover and chain |

| Display | Standard | High Brightness Optional |
|--------------------------------|---------------|--------------------------|
| Display Type | 15" TFT-LCD | 15" TFT-LCD |
| Max. Resolution | 1024 x 768 | 1024 x 768 |
| Max. Color | 16.7M / 262K | 16.2M / 262K |
| Luminance (cd/m ²) | 450 | 1000 |
| View Angle | 160(H)/150(V) | 160(H)/150(V) |
| Contrast | 800:1 | 800:1 |
| Backlight Lifetime | 70,000 hrs | 50,000 hrs |

| Touch Screen | |
|-----------------------|----------------------------|
| Type | Projected Capacitive Touch |
| Interface | USB |
| Light Transmission(%) | 90% |

| Power | |
|-------------------|---------------|
| Power Input | DC 9~36V |
| Power Consumption | AEx-115P: 17W |

| Mechanical | |
|--------------|--|
| Construction | 316 stainless steel chassis |
| Mounting | VESA mount 100 x 100, Panel mount (option) |
| IP Rating | Total IP66 |
| Dimensions | 399 x 324 x 70 mm |
| Net Weight | 8.5 kg |

| Environmental | |
|-----------------------|--|
| Operating Temperature | -20~60°C |
| Storage Temperature | -30~70°C |
| Humidity | 10 to 95% @ 40°C, non-condensing |
| Safety | CSA C22.2 No.61010 |
| Certificate | CE / FCC Class A, ATEX Zone2 Ex nA ic IIC T4 Gc Class I, Division2, Group ABCD T4 ANSI/ISA 12.12.01-2013 CSA Std. C22.2 No213-1987 |

Dimensions

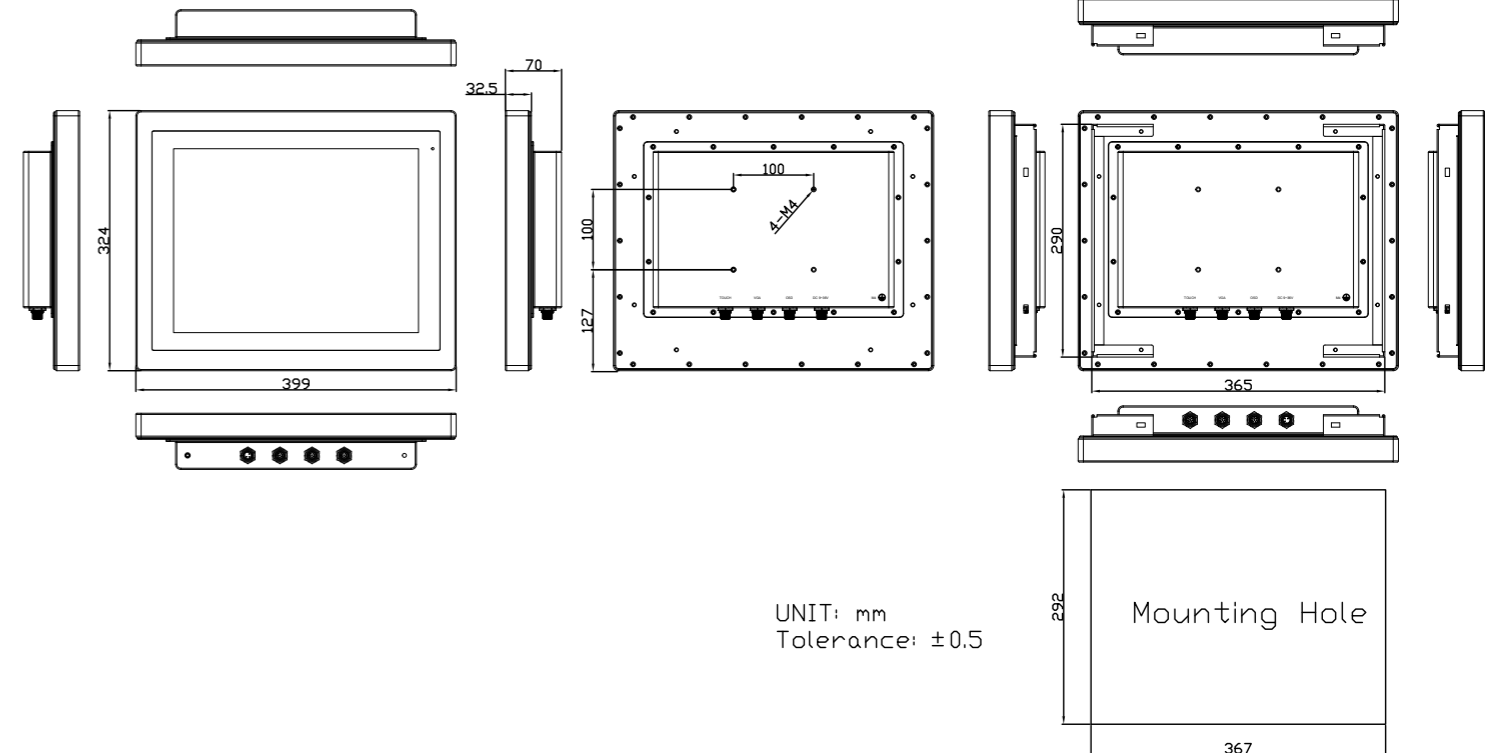

Ordering Information

| | |
|-----------|--|
| AEX-115P | 15" XGA IP66, 316 Stainless display, VGA input, external OSD box, Projected capacitive touch, 9~36V DC Power input, VESA Mount, WT-20~60 Accessory : 1 x M12 for USB touch cable, 1 x VGA Cable, 1 x 3pin power input cable (w/o Adapter) |
| AEX-115PH | 15" XGA HB1000nits, 316 Stainless display, VGA input, external OSD box, Projected capacitive touch, 9~36V DC Power input, VESA Mount, WT-20~60 Accessory : 1 x M12 for USB touch cable, 1 x VGA Cable, 1 x 3pin power input cable (w/o Adapter) |