

W26L100-MRA1FP

26" ECDIS Marine Display



KEY FEATURES

- 26" 1920 x 1200 resolution with projective capacitive multi-touch screen
- Edge-to-edge narrow bezel design and fanless cooling system, ECDIS Marine Display
- Color calibrated for ECDIS compliance (Optional)
- Capacitive touch keys for quick function access and display control (Support ECDIS DAY, DUSK, and NIGHT mode switching)
- Meet the requirements of industrial marine standards, including IEC60945 4th Edition, DNVGL-CG-0339, IACS E10



SPECIFICATIONS

Display			
Resolution	1920x1200	Size	26 inches
Contrast Ratio	1500:1	Panel Brightness	350 nits
Display Color	16.7M Colors	View Angles	88,88,88,88
Active Area	550.08 x 343.8 mm	Touch / Glass	Projected Capacitive Multi Touch Screen (AR Film) AG film (Optional) AR Glass (Optional)
Environment			
Operating Humidity	5% to 95%	Operating Temperature	-15~55°C
Shock	15G, 11ms duration	Vibration	0.7g@DNVGL CG-0339 (Class A)
IP rating	IP66 (Front Side)		
Certification			
Certification	DNVGL-CG-0339, IEC60945 4th, IACS E10, CE, FCC		
IO Ports			
USB Port	1 x USB Type A	Serial Port	1 x RS232 for remote control
Video	1 x VGA 1 x DVI-D 1 x HDMI 1.4	Front Control	Power Brightness+ Brightness- OSD/ Enter ECDIS Key/ ESC
Indicator	Day Mode Dusk Mode Night Mode		
Mechanical			
Dimension	621 x 432.4 x 85.5 mm	Weight	12.8 kg
Mounting	VESA Mount/ Panel Mount	Enclosure	Anodized Aluminum Bezel
Cooling System	Fanless Design	Cut out	596 x 406 mm
Power			
Power Rating	24V DC-in with Isolation (Approval by Certificate) 9~36V DC Input Acceptable	Consumption	55W (Typical)

Accessory

Accessory

User Manual
Quick Start Guide (Hardcopy)
M4 x 12 Black Screw Bolts
AC to DC Adapter
Power Cord
3 Pin Terminal Block
1 x VGA cable
1 x DVI cable
1 x HDMI cable
1 x RS232 cable

Optional Accessory 1 x USB cable

DIMENSIONS

UNIT:MM

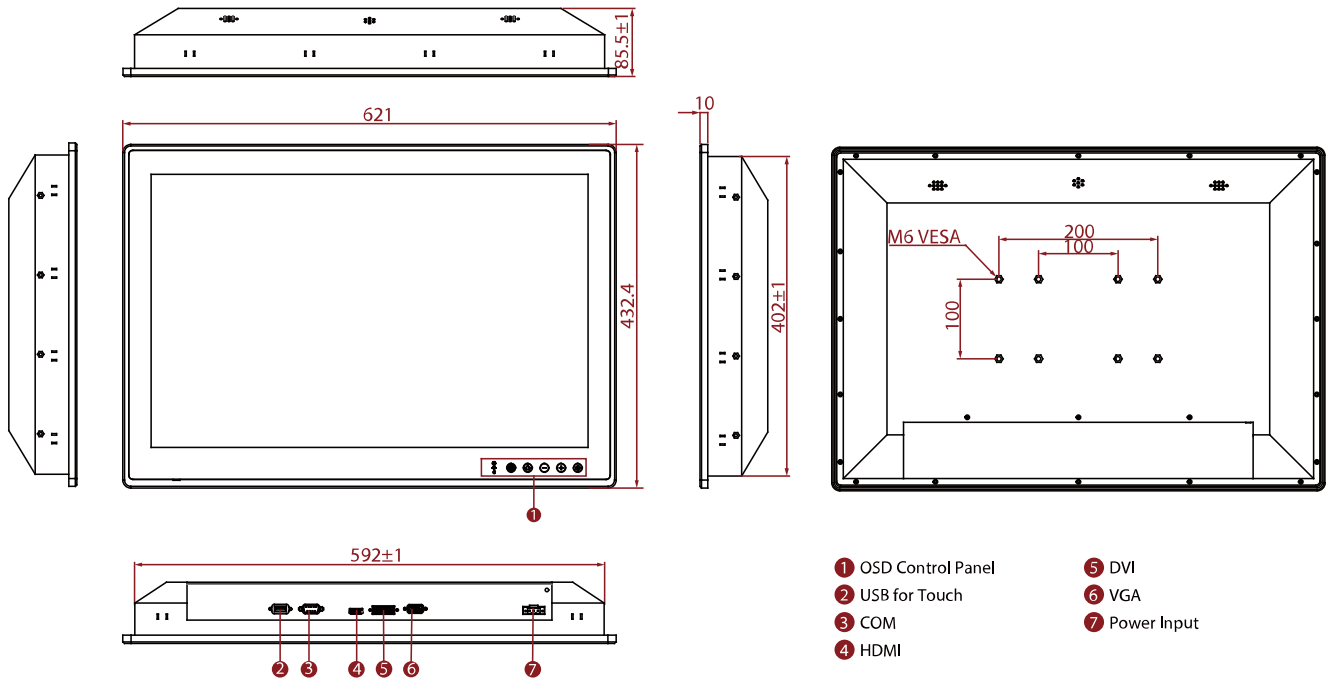

NOTE

1. This is a simplified drawing and some components are not marked in detail.
2. Please contact our sales representative if you need further product information.
3. All specifications are subject to change without prior notice.
4. The product shown in this datasheet is a standard model. For diagrams that contain customized or optional I/O, please contact the Winmate Sales Team for more information.