

R12T600-PML1HB

12.1" Panel Mount High Brightness Display



KEY FEATURES

- 12.1", 800 x 600 Panel Mount High Brightness Display
- VGA and HDMI input
- Panel mount
- VESA mount
- High brightness



SPECIFICATIONS

Display	
Resolution	800x600
Contrast Ratio	700:1
Display Color	16.2M Colors
Active Area	246x184.5 mm
Size	12.1 inches
Panel Brightness	1000.0 nits
View Angles	80,80,75,65
Touch / Glass	Resistive Touch Screen Protection Glass w/o Touch Function (Optional) SAW Touch (Surface Acoustic Wave) (Optional)
Environment	
Operating Humidity	10% to 90% RH, Non-Condensing
Storage Temperature	-10°C to 60°C
Operating Temperature	0°C to 50°C
Certification	
Certification	CE, FCC
IO Ports	
USB Port	1 x USB for Touch Screen
Audio	Audio line in (3.5mm) (Optional) 2 x Speaker (Optional)
Video	1 x VGA 1 x HDMI (Optional) 1 x DVI (Optional)
Mechanical	
Dimension	324 x 274 x 43 mm
Enclosure	Metal Housing with Aluminum Bezel
Cut out	303 x 222 mm
Mounting	VESA Mount/ Panel Mount
Cooling System	Fanless Design
Accessory	
Accessory	1 x VGA cable 1 x HDMI cable 100~240V AC to DC Adapter Power Cord Manual VESA screws(Varies by product)
Optional Accessory	Remote Controller (Optional,Varies by product)
Power	
Power Rating	12V DC in 24V DC in (optional)

Control

Button 5 Keys: -, +, Power, Esc, Enter

DIMENSIONS UNIT:MM

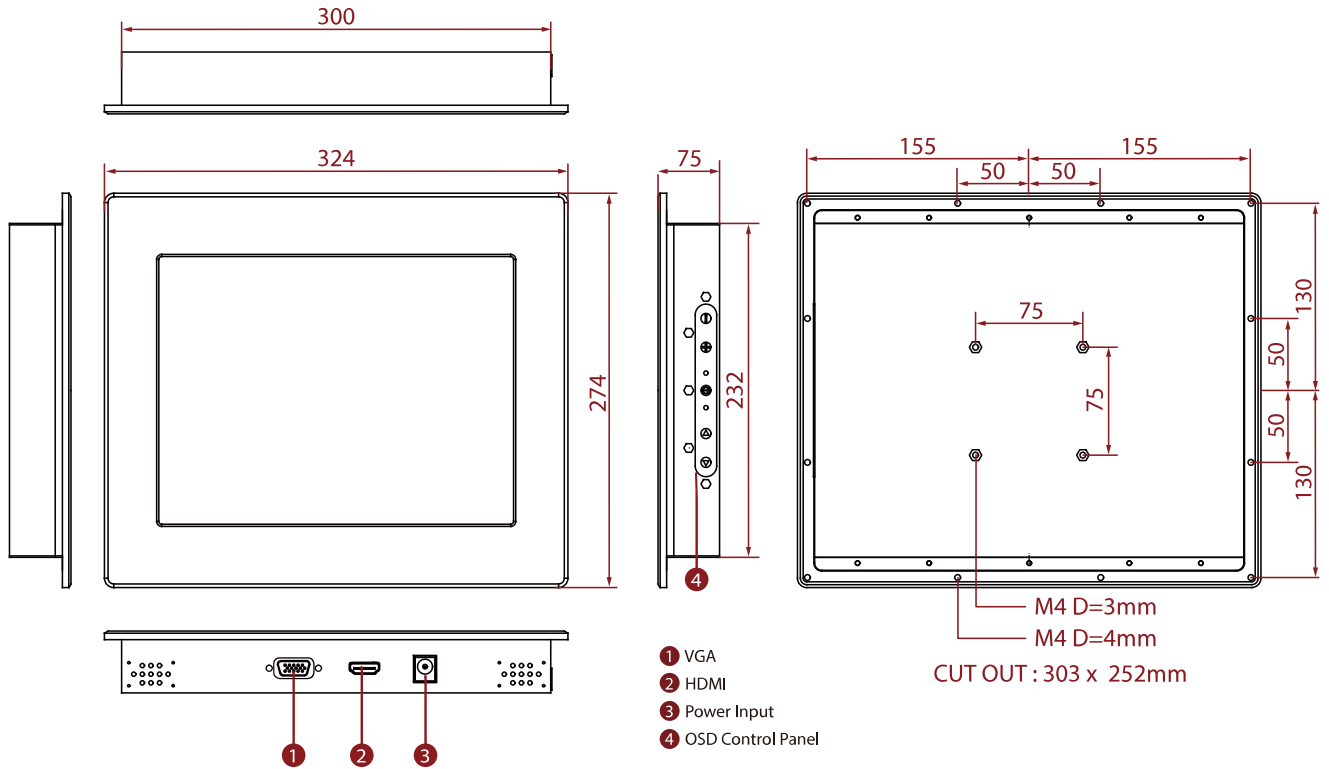

NOTE

1. This is a simplified drawing and some components are not marked in detail.
2. Please contact our sales representative if you need further product information.
3. All specifications are subject to change without prior notice.
4. The product shown in this datasheet is a standard model. For diagrams that contain customized or optional I/O, please contact the Winmate Sales Team for more information.