

M133WKU

13.3" Industrial Ruggedized Tablet with Intel® Core™ i5-8265U



KEY FEATURES

- Intel® Core™ i5-8265U Whiskey Lake processor industrial tablet
- 13.3" 1920 x 1080 IPS wide viewing angle LED Panel
- Magnesium alloy housing with all-around elastomeric rubber
- Built-in kickstand usable as carrying handle(indefinitely adjustable)
- Cold swap Battery Pack
- IP65 waterproof and dustproof
- Optical bonding technology
- TPM 2.0



SPECIFICATIONS

Display			
Resolution	1920x1080	Size	13.3 inches
Contrast Ratio	1000:1	Panel Brightness	500 nits
View Angles	89,89,89,89	Type	Projected Capacitive Multi Touch
Bonding	Optical Bonding for Sunlight Viewability		
System Specification			
Processor	Intel Core i5-8265U 1.6GHz (up to 3.9GHz)	Memory	4GB SODIMM DDR4-2400 8GB SODIMM DDR4-2400 (Optional) 16GB SODIMM DDR4-2400 (Optional)
Storage	Storage 1: 1 x 128GB M.2 SSD Additional storage available with SDXC card slot Storage 1 up to 1x 1TB M.2 SSD (Optional) Storage 2 up to 1x 1TB M.2 SSD (Optional)	Ethernet controller	1 x RJ45-10/100/1000 Mbps LAN
Security	Trusted Platform Module (TPM) 2.0 Kensington Lock	Operating System	Ubuntu 18.04
WLAN	Support	BT	Support
WWAN	4G LTE (Optional)	GNSS	GPS/GLONASS (Optional)
Mechanical			
Dimension	338.2 x 240 x 30 mm (13.3 x 9.4 x 1.18 inches)	Weight	2.2kg (w/ kickstand)
Cooling System	Fanless thermal design		
IO Ports			
USB Port	4 x USB 3.0 Type A, 1 x USB 3.0 Type C	SD Card Slot	1 x SDXC Slot
SIM Card Slot	1 x Micro SIM card slot	Audio	2 x 1 watt speaker
LAN	1 x RJ45-10/100/1000 Mbps LAN	Indicator	4x LED Indicator for Power, Battery, SSD, RF status
Docking Connector	1 x Docking connector		
Environment			
Operating Humidity	30% to 80% RH, non-condensing	Operating Temperature	-10°C to 50°C (14°F to 122°F)
Storage Temperature	-20°C to 60°C (-4°F to 140°F)	Shock	MIL-STD-810G Method 516.6 Procedure I
Vibration	MIL-STD-810G Method 514.6 Procedure I	IP rating	IP65

Drop	MIL-STD-810G Method 516.6, 4 ft		
Certification			
Certification	CE, FCC		
Security Function			
Kensington Lock	Kensington Lock Support		
Control			
Button	1 x Power, 1 x menu, 2 x volume key 3 x Programmable Function Keys		
Power			
Battery	15.4V, typ. 5900 mAh Li-Polymer Battery (4S1P)	Battery Operating Time	More than 10 hours (BAPCo TabletMark v3)
Power Rating	19V DC	Adapter	100-240V, 50-60Hz / 19V DC
Accessory			
Accessory	Adapter and Power Cord Standard Battery Stylus Stand with Integrated Handle	Optional Accessory	Vehicle Charger (Optional) Battery Charger (Optional) Desk Docking (Optional)

DIMENSIONS UNIT:MM

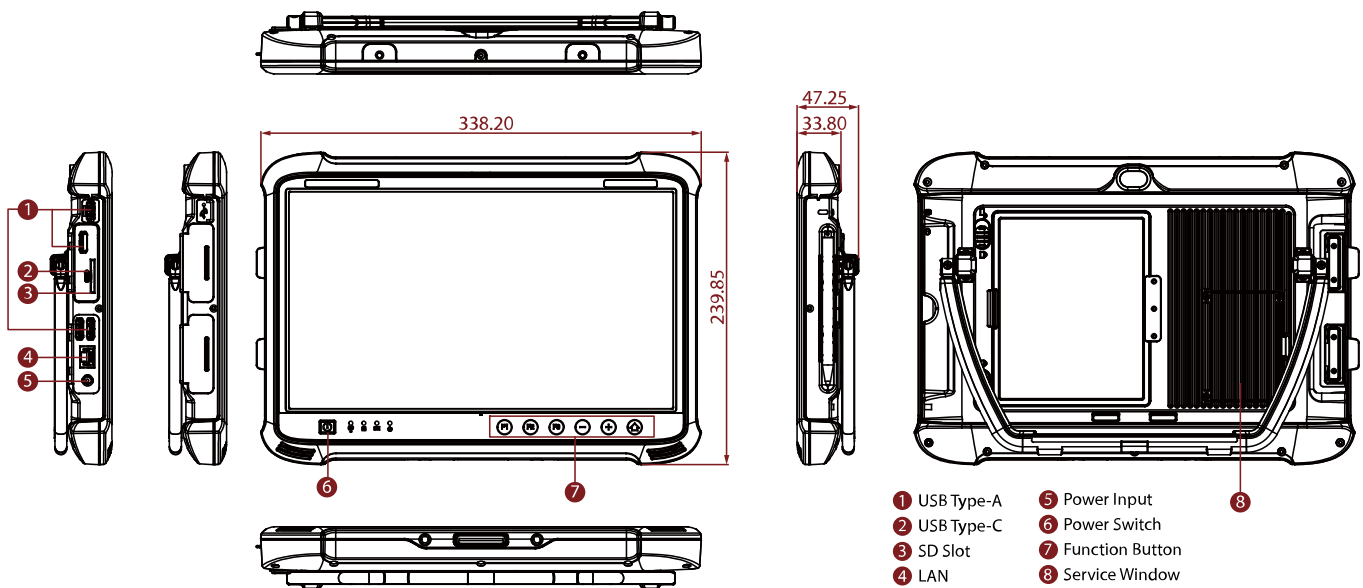

NOTE

1. Total usable memory will be less dependent upon actual system configuration.
2. TPM 2.0 is available upon request.
3. Length measurements do not include protrusions. Weight varies with options.
4. Measured at dimming LCD brightness. Varies depending on the usage conditions, or when an external device is attached.
5. This is a simplified drawing and some components are not marked in detail.
6. The product shown in this datasheet is a standard model. For diagrams that contain customized or optional I/O, please contact the Winmate Sales Team for more information.