

Introduction

The XF1000 is a 10.4 inches high grade monitor, including AFFS+ technology (superior to transfective technology) with 350nits (T) and 1000nits (HB) brightness. The HB version achieves including a high efficiency backlight rated 1000nits at only 5.5W power consumption. In addition, T version reaches 800nits and HB version reaches 1500nits under direct sunlight, due to its transfectivity.

The XF1000 includes a high featured controller including automatic and manual backlight adjustment, depending of the ambient light, which makes it suitable for applications from the darkest night (NVIS) to the bright sun light. Besides, the XF1000 optionally includes a resistive touch panel with USB controller, adding interactivity.

The XF1000 is available with VGA and Audio input as standard, optional DVI, Composite Video and S-Video inputs. All inputs are available as factory option on the rear panel. Optionally it includes "all in one cable", with a lockable connector for an easy and quick installation.



- IPS XGA Version XF1000T -

Features

- * High quality image with wide viewing angle.
- * High efficiency backlight.
- * Sunlight readable.
- * Backlight control, suitable from night vision to outdoor daylight applications.
- * IP65 chasis.
- * Designed for continuous vibration environments.
- * Wide input voltage range with transient protection.
- * Standard VESA mount.



Drawing

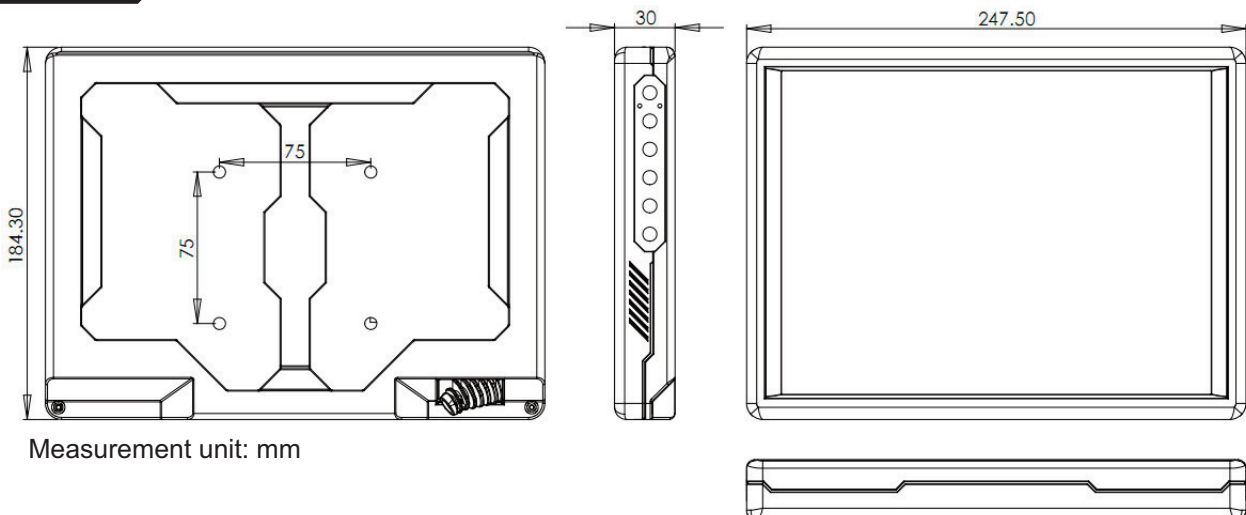

Specifications

Size	10.4 inches
Aspect	4 : 3
Inputs	VGA, DVI, HDMI, 2 / 3 x Composite Video
Audio	2 x 1.8 W
Touch Panel	Resistive 4 wires USB/RS232. Endurance >2M touch.
Power supply	9-36VDC automotive car/truck suitable.
Total power consumption	T: 8W / HB: 10W
Mounting	Stand alone and headrest accesories.
Warranty	12 months international, 24 months Europe.
Certification	CE, e-mark*

Mechanical and environmental specs

Dimensions	247.5x184.3x31mm
Weight	900gr
Enclosure	Aluminium chasis/rear. PVC-ABS front.
Operation temperature.	-35°C to 75°C max (-20°C to 70°C continuous)
Storage temperature.	-40°C to 85°C
Vibrations	1G 2-500Hz
Shock	20G 11ms
Drop	10cm max.
Mounting	VESA 75mm mounting holes, Stand alone brackets and windshield suction accesories.

Optical specifications

Brightness	T: 350nits native transfective(800nits equivalent under sunlight). HB: 1000nits native transfective(1500nits equivalent under sunlight).
Contrast	700:1
Colors	256K
Native resolution	1024x768px
Outdoor readability	Meets MIL-STD-3009 (sunlight readable version XF1000T/HB-US/RS)
NVIS	Optional NVIS B compliant

ORDER INFORMATION

Code and Options:

	XF1000HB-X Y V A C - NB	NB: non bonded option for sun- light/daylight readable versions
High Brightness	_____	
X - Touch Screen Option	_____	C - Cable Option
U : USB	_____	2 : 2.5 meters
R : RS232	_____	4 : 4.5 meters
N : W/O Touch Panel	_____	C : Custom Cable
Y - Usage Option	_____	A - Audio Option
N : Normal	_____	N : W/O Audio
D : Day Light Readable	_____	A : Stereo Audio
S : Sun Light Readable	_____	V - Video Option
		V : Video Input
		N : W/O Video

Example: XF1000HB-USVA2 10.4" high brightness monitor with USB Touch Panel, Sunlight readable ,Video, Stereo Audio with 2.5 meters lenth cable.