

15" GC65 Panel PC (Standard I/O) - R15IP3S-GCC3

Features

- 15" 1024 x 768 PCAP multi-touchscreen
- Intel® Pentium® N4200 Apollo Lake Processor
- Fanless cooling system and ultra-low power consumption
- Dual Gigabit Ethernet
- Front IP65 water and dust proof
- Stylish design for room booking, access control and room information applications

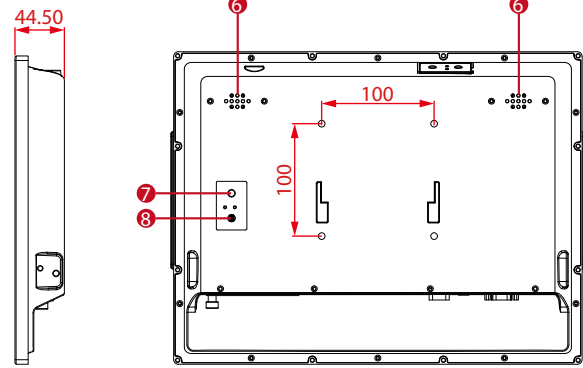
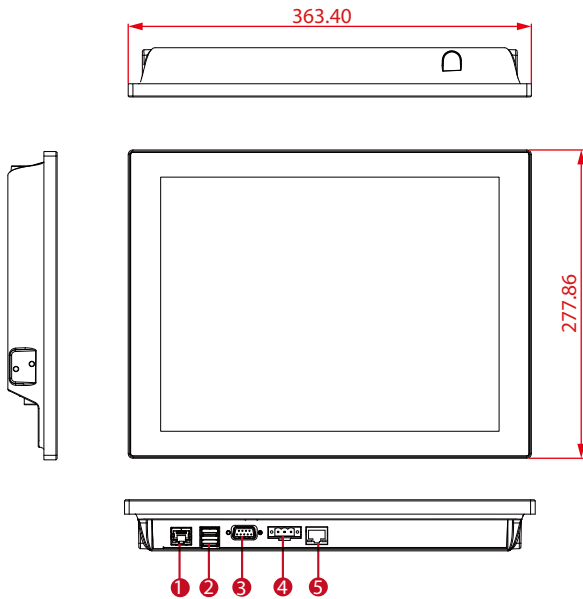

- | | |
|--------------------------|-----------------------|
| 1. RJ-45 (LAN) | 5. RJ-45 (LAN) |
| 2. USB 3.0 | 6. 1 Watt Speaker x 2 |
| 3. RS232/422/485 | 7. Power on Button |
| 4. 12V DC Terminal Block | 8. Power Reset Button |

Specifications

System

- Processor : Intel® Pentium® Processor N4200 (2M Cache, up to 2.5 GHz)
- System Memory : 2GB DDR3L 1866 SO-DIMM (Optional 8 GB)
- Storage : 64GB M.2 SSD (Default)
- LAN : Dual Intel® I210-AT GbE LAN

Input / Output

- Serial Port : 1 x RS-232/422/485
- USB Port : 2 x USB 3.0
- Ethernet : 1 x RJ-45-10/100/1000 Mbps, 1 x RJ-45

Environment Considerations

- Operating Temperature : 0 °C to 50 °C
- Operating Humidity : 10% to 90% (non-condensing)
- IP Rating : Front IP65

Power Spec

- Power Input : 12V DC in
- Power Consumption : 24W

Display Spec

- Panel Size : 15" TFT
- Resolutions : 1024 x 768
- Brightness : 250 cd/m (typ.)
- Contrast Ratio : 2000:1 (typ.)
- Viewing Angle : -88~88 (H) ; -88~88 (V)
- Max Colors : 16.2M
- Touch screen : Projected Capacitive Multi-Touch

Mechanical Spec

- Mounting : VESA Mount (100x100mm), Panel Mount
- Dimensions (W x H x D) : 363.40 x 277.86 x 44.50 (mm)
- Cutout Dimensions : 345.4 x 260 (mm)

Operating System

- Windows 10 IoT Enterprise

Security Support

- Trusted Platform Module (TPM 2.0)

