



ACCES I/O PRODUCTS INC
10623 Roselle Street, San Diego, CA 92121
TEL (858)550-9559 FAX (858)550-7322

MODEL RDAG12-8(H)

USER MANUAL

FILE: MRDAG12-8H.Bc

Notice

The information in this document is provided for reference only. ACCES does not assume any liability arising out of the application or use of the information or products described herein. This document may contain or reference information and products protected by copyrights or patents and does not convey any license under the patent rights of ACCES, nor the rights of others.

IBM PC, PC/XT, and PC/AT are registered trademarks of the International Business Machines Corporation.

Printed in USA. Copyright 2000 by ACCES I/O Products Inc, 10623 Roselle Street, San Diego, CA 92121. All rights reserved.

Warranty

Prior to shipment, ACCES equipment is thoroughly inspected and tested to applicable specifications. However, should equipment failure occur, ACCES assures its customers that prompt service and support will be available. All equipment originally manufactured by ACCES which is found to be defective will be repaired or replaced subject to the following considerations.

Terms and Conditions

If a unit is suspected of failure, contact ACCES' Customer Service department. Be prepared to give the unit model number, serial number, and a description of the failure symptom(s). We may suggest some simple tests to confirm the failure. We will assign a Return Material Authorization (RMA) number which must appear on the outer label of the return package. All units/components should be properly packed for handling and returned with freight prepaid to the ACCES designated Service Center, and will be returned to the customer's/user's site freight prepaid and invoiced.

Coverage

First Three Years: Returned unit/part will be repaired and/or replaced at ACCES option with no charge for labor or parts not excluded by warranty. Warranty commences with equipment shipment.

Following Years: Throughout your equipment's lifetime, ACCES stands ready to provide on-site or in-plant service at reasonable rates similar to those of other manufacturers in the industry.

Equipment Not Manufactured by ACCES

Equipment provided but not manufactured by ACCES is warranted and will be repaired according to the terms and conditions of the respective equipment manufacturer's warranty.

General

Under this Warranty, liability of ACCES is limited to replacing, repairing or issuing credit (at ACCES discretion) for any products which are proved to be defective during the warranty period. In no case is ACCES liable for consequential or special damage arising from use or misuse of our product. The customer is responsible for all charges caused by modifications or additions to ACCES equipment not approved in writing by ACCES or, if in ACCES opinion the equipment has been subjected to abnormal use. "Abnormal use" for purposes of this warranty is defined as any use to which the equipment is exposed other than that use specified or intended as evidenced by purchase or sales representation. Other than the above, no other warranty, expressed or implied, shall apply to any and all such equipment furnished or sold by ACCES.

Table of Contents

Chapter 1: Introduction	1-1
Description	1-1
Specifications	1-3
Chapter 2: Installation	2-1
CD Installation	2-1
Directories Created on the Hard Disk	2-1
Getting Started	2-3
Calibration	2-6
Installation	2-6
Input/Output Pin Connections	2-6
Chapter 3: Software	3-1
General	3-1
Command Structure	3-1
Command Functions	3-3
Error Codes	3-10
Appendix A: Application Considerations	A-1
Introduction	A-1
Balanced Differential Signals	A-1
RS485 Data Transmission	A-3
Appendix B: Thermal Considerations	B-1

List of Figures

Figure 1-1: RDAG12-8 Block Diagram	Page 1-6
Figure 1-2: RDAG12-8 Hole Spacing Diagram	Page 1-7
Figure 2-1: Simplified Schematic for Voltage and Current Sink Outputs	Page 2-9
Figure A-1: Typical RS485 Two-Wire Multidrop Network	Page A-3

List of Tables

Table 2-1: 50 Pin Connector Assignments	Page 2-7
Table 3-1: RDAG12-8 Command List	Page 3-2
Table A-1: Connections Between Two RS422 Devices	Page A-1
Table A-2: RS422 Specification Summary	Page A-2

Chapter 1: Introduction

Features

- Remote Intelligent Analog Output and Digital I/O Units with Opto-Isolated RS485 Serial Interface to Host Computer
- Eight 12-Bit Analog Current Sinks (4-20mA) and Voltage Outputs
- Software Selectable Voltage Ranges of 0-5V, 0-10V, $\pm 5V$
- Low-Power and High-Power Analog Output Models
- Seven Bits of Digital I/O Configured on a Bit-by-Bit Basis as either Inputs or High-Current Outputs
- Field Connections Accomplished via 50-pin Removable Screw Terminals
- Onboard 16-bit 8031 Compatible Microcontroller
- All Programming and Calibration in Software, No Switches to Set. Jumpers Available to By-Pass Opto-Isolators if Desired
- Protective NEMA4 Enclosure for Harsh Atmospheric and Marine Environments for Low-Power Standard Model
- Protective Metal T-Box for High-Power Model

Description

RDAG12-8 is an intelligent, 8-channel, digital-to-analog converter unit that communicates with the host computer via EIA RS-485, Half-Duplex, serial communications standard. ASCII-based command/response protocol permits communication with virtually any computer system. RDAG12-8 is one of a series of remote intelligent Pods called the "REMOTE ACCES Series". As many as 32 REMOTE ACCES Series Pods (or other RS485 devices) may be connected on a single two or four-wire multidrop RS485 network. RS485 repeaters may be used to extend the number of Pods on a network. Each unit has a unique address. Communication uses a master/slave protocol wherein the Pod talks only if questioned by the computer.

An 80C310 Dallas microcontroller (with 32k x 8 bits RAM, 32K bits non-volatile EEPROM, and a watchdog timer circuit) gives RDAG12-8 the capability and versatility expected from a modern distributed control system. RDAG12-8 contains CMOS low-power circuitry, an optically-isolated receiver/transmitter, and power conditioners for local and external isolated power. It can operate at baud rates up to 57.6 Kbaud and distances up to 4000 feet with low-attenuation twisted-pair cabling, such as Belden #9841 or equivalent. Data collected by the Pod can be stored in local RAM and accessed later through the computer's serial port. This facilitates a stand-alone Pod mode of operation.

RDAG12-8 Manual

All programming of RDAG12-8 is in ASCII-based software. ASCII-based programming permits you to write applications in any high-level language that supports ASCII string functions.

The module, or Pod, address is programmable from 00 to FF hex and whatever address is assigned is stored in EEPROM and used as the default address at the next Power-ON. Similarly, the baud rate is programmable for 1200, 2400, 4800, 9600, 14400, 19200, 28800, and 57600. The baud rate is stored in EEPROM and used as default at the next Power-ON.

Analog Outputs

These units consist of eight independent 12-bit digital-to-analog converters (DACs), and amplifiers for voltage outputs and voltage-to-current conversion. The DACs may be updated in a channel-by-channel mode or simultaneously. There are eight channels of voltage output and eight complimentary channels for 4-20mA current output sinks. The output voltage ranges are software selectable. Calibration is performed by software. Factory calibration constants are stored in the EEPROM memory and can be updated by disconnecting the I/O wiring and entering the software calibration mode. Model RDAG12-8 can supply analog outputs of up to 5 mA on voltage ranges of 0-5V, $\pm 5V$, and 0-10V. By writing discrete values of a desired waveform into the buffers and loading the buffers into the DAC at a programmable rate (31-6,000Hz) the units can generate arbitrary waveforms or control signals.

Model RDAG12-8H is similar except that each DAC output can drive loads up to 250mA using a $\pm 12V @ 2.5A$ local power supply. RDAG12-8H is packaged in a non-sealed "T-Box" steel enclosure.

Digital I/O

Both models also have seven digital input/output ports. Each port can be individually programmed as an input or an output. Digital input ports can accept logic high input voltages up to 50V and are overvoltage protected to 200 VDC. Output drivers are open collector and can comply with up to 50 VDC of user-supplied voltage. Each output port can sink up to 350 mA but total sink current is limited to a cumulative total of 650 mA for all seven bits.

Watchdog Timer

The built-in watchdog timer resets the Pod if the microcontroller "hangs up" or the power supply voltage drops below 7.5 VDC. The microcontroller may also be reset by an external manual pushbutton connected to /PBRST (pin 41 of the interface connector).

Specifications

Serial Communications Interface

- Serial Port: Opto-isolated Matlabs type LTC491 Transmitter/Receiver. Compatible with RS485 specification. Up to 32 drivers and receivers allowed on the line. I/O bus programmable from 00 to FF hex (0 to 255 decimal). Whatever address is assigned is stored in EEPROM and used as default at next Power-On.
- Asynchronous Data Format: 7 data bits, even parity, one stop bit.
- Input Common Mode Voltage: 300V minimum (opto-isolated). If opto-isolators are by-passed: -7V to +12V.
- Receiver Input Sensitivity: ± 200 mV, differential input.
- Receiver Input Impedance: 12K Ω minimum.
- Transmitter Output Drive: 60 mA, 100 mA short circuit current capability.
- Serial Data Rates: Programmable for 1200, 2400, 4800, 9600, 14400, 19200, 28800, and 57600 baud. Crystal oscillator provided.

Analog Outputs

- Channels: Eight independent.
- Type: 12-bit, double-buffered.
- Non-Linearity: ± 0.9 LSB maximum.
- Monotonicity: $\pm 1/2$ bit.
- Output Range: 0-5V, ± 5 V, 0-10V.
- Output Drive: Low Power Option: 5 mA, High Power Option: 250 mA.
- Current Output: 4-20 mA SINK (User supplied excitation of 5.5V-30V).
- Output Resistance: 0.5.
- Settling Time: 15 μ sec to $\pm 1/2$ LSB.

Digital I/O

- Seven bits configured as input or output.
- Digital Inputs Logic High: +2.0V to +5.0V at 20 μ A max. (5mA max at 50V in)
Protected to 200 VDC
- Logic Low: -0.5V to +0.8V at 0.4 mA max. Protected to -140 VDC.
- Digital Outputs Logic-Low Sink Current: 350 mA maximum. (See note below.)
Inductive kick suppression diode included in each circuit.

Note

Maximum allowable current per output bit is 350 mA. When all seven bits are used, there is a maximum total current of 650 mA.

- High-Level Output Voltage: Open Collector, compliance with up to 50VDC user-supplied voltage. If no user supplied voltage exists, outputs pulled up to +5VDC via 10 k Ω resistors.

Interrupt Input (For use with development kit)

RDAG12-8 Manual

- Input Low: -0.3V to +0.8V.
- Input Low Current at 0.45V: -55µA.
- Input High: 2.0V to 5.0V.

Environmental

The environmental characteristics depend on the RDAG12-8 configuration.

Low and High power output configurations:

- Operating Temperature Range: 0 °C. to 65 °C. (Optional -40 °C. to +80 °C.).
- Temperature De-rating: Based on the power applied, maximum operating temperature may have to be de-rated because internal power regulators dissipate some heat. For example, when 7.5VDC is applied, the temperature rise inside the enclosure is 7.3°C above the ambient temperature.

Note

Maximum operating temperature can be determined according to the following equation:

$$V_{I(TJ=120)} < 22.5 - 0.2T_A$$

Where T_A is the ambient temperature in °C. and $V_{I(TJ=120)}$ is the voltage at which the integral voltage regulator junction temperature will rise to a temperature of 120 °C.

(Note: The junction temperature is rated to 150 °C. maximum.)

For example, at an ambient temperature of 25 °C., the voltage V_I can be up to 17.5V.

At an ambient temperature of 100 °F. (37.8 °C.), the voltage V_I can be up to 14.9V.

- Humidity: 5% to 95% RH non-condensing.
- Size: NEMA-4 Enclosure 4.53" long by 3.54" wide by 2.17" high.

Power Required

Power can be applied from the computer's +12VDC power supply for the opto-isolated section via the serial communication cable and from a local power supply for the rest of the unit. If you do not wish to use power from the computer, a separate power supply isolated from the local power supply may be used for the opto-isolated section. The power used by this section is minimal (less than 0.5W).

Low power version:

- Local Power: +12 to 18 VDC @ 200 mA. (See box that follows.)
- Opto-Isolated Section: 7.5 to 25 VDC @ 40 mA. (Note: Due to the small amount of current required, voltage drop in long cables is not significant.)

High power version:

- Local Power: +12 to 18 VDC at up to 2 ½ A, and -12 to 18V at 2A depending on the output load drawn.
- Opto-Isolated Section: 7.5 to 25 VDC @ 50 mA. (Note: Due to the small amount of current required, voltage drop in long cables is not significant.)

Note

If the local power supply has an output voltage greater than 18VDC, you can install a Zener diode in series with the supply voltage. The voltage rating of the Zener diode (V_z) should be equal to $V_1 - 18$ where V_1 is the power supply voltage. The power rating of the Zener diode should be $\geq V_z \times 0.12$ (watts). Thus, for example, a 26VDC power supply would require using an 8.2V Zener diode with a power rating of $8.2 \times 0.12 \approx 1$ watt.

RDAG12-8 Manual

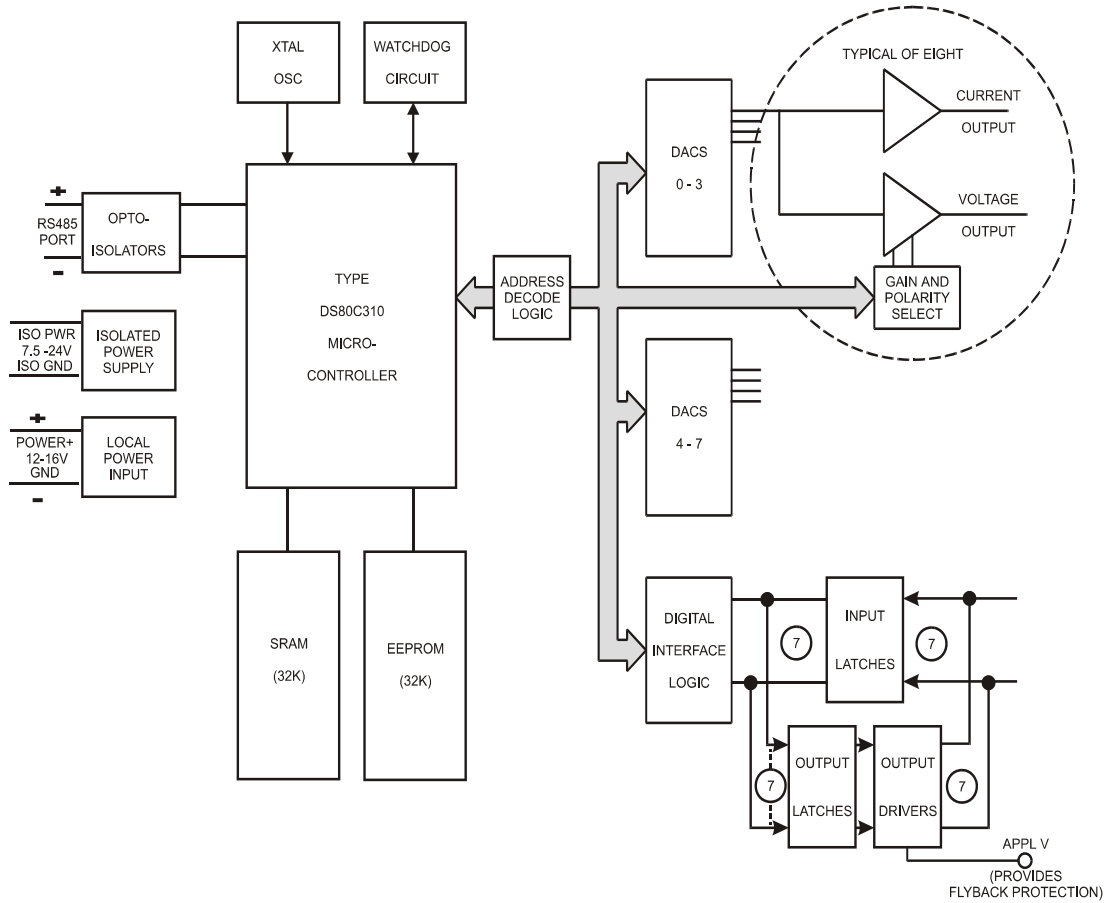

Figure 1-1: RDAG12-8 Block Diagram

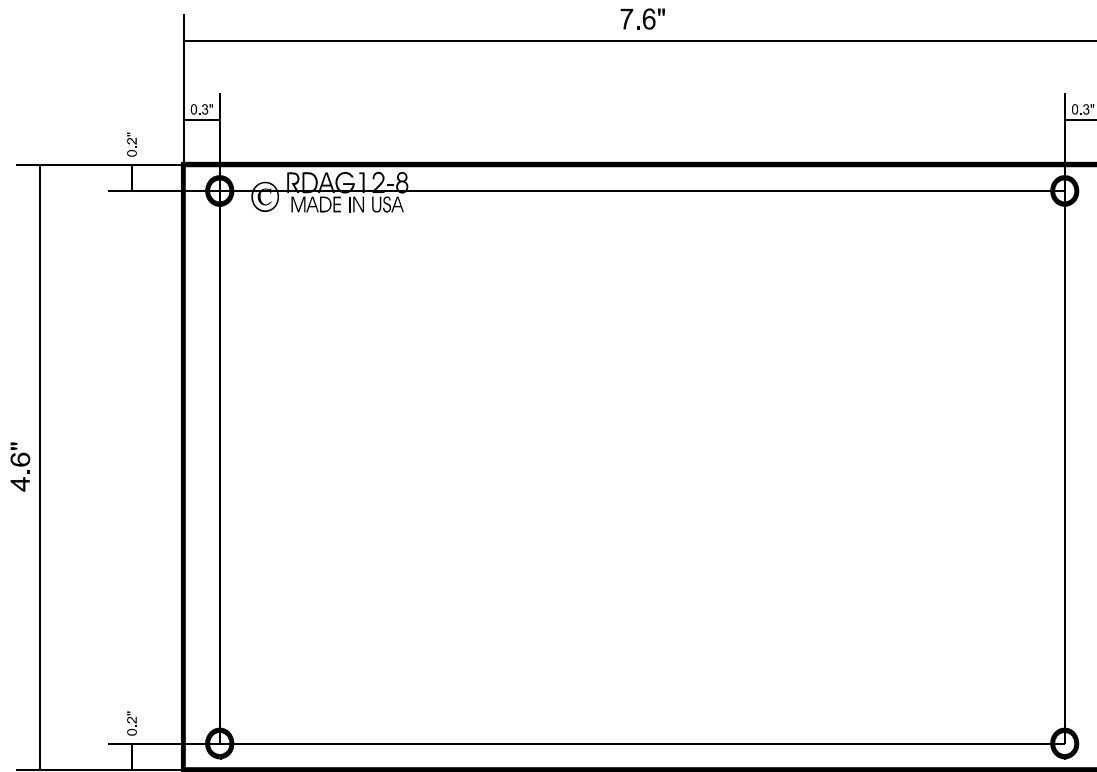

Figure 1-2: RDAG12-8 Hole Spacing Diagram

Chapter 2: Installation

The software provided with this card is contained on CD and must be installed onto your hard disk prior to use. To do this, perform the following steps applicable for your operating system. Substitute the appropriate drive letter for your CD-ROM where you see `d:` in the examples below.

CD Installation

WIN95/98/NT/2000

- a. Place the CD into your CD-ROM drive.
- b. The install program should automatically run after 30 seconds. If the install program does not run, click START | RUN and type `d:install`, click OK or press **Enter**.
- c. Follow the on-screen prompts to install the software for this card.

Directories Created on the Hard Disk

The installation process will create several directories on your hard disk. If you accept the installation defaults, the following structure will exist.

[CARDNAME]

Root or base directory containing the SETUP.EXE setup program used to help you configure jumpers and calibrate the card.

- DOS\PSAMPLES:** A subdirectory of [CARDNAME] that contains Pascal samples.
DOS\CSAMPLES: A subdirectory of [CARDNAME] that contains "C" samples.
Win32\language: Subdirectories containing samples for Win95/98 and NT.

WinRISC.exe

A Windows dumb-terminal type communication program designed for RS422/485 operation. Used primarily with Remote Data Acquisition Pods and our RS422/485 serial communication product line. Can be used to say hello to an installed modem.

ACCES32

This directory contains the Windows 95/98/NT driver used to provide access to the hardware registers when writing 32-bit Windows software. Several samples are provided in a variety of languages to demonstrate how to use this driver. The DLL provides four functions (InPortB, OutPortB, InPort, and OutPort) to access the hardware.

This directory also contains the device driver for Windows NT, ACCESNT.SYS. This device driver provides register-level hardware access in Windows NT. Two methods of using the driver are available, through ACCES32.DLL (recommended) and through the DeviceIOControl handles provided by ACCESNT.SYS (slightly faster).

RDAG12-8 Manual

SAMPLES

Samples for using ACCES32.DLL are provided in this directory. Using this DLL not only makes the hardware programming easier (MUCH easier), but also one source file can be used for both Windows 95/98 and WindowsNT. One executable can run under both operating systems and still have full access to the hardware registers. The DLL is used exactly like any other DLL, so it is compatible with any language capable of using 32-bit DLLs. Consult the manuals provided with your language's compiler for information on using DLLs in your specific environment.

VBACCES

This directory contains sixteen-bit DLL drivers for use with VisualBASIC 3.0 and Windows 3.1 only. These drivers provide four functions, similar to the ACCES32.DLL. However, this DLL is only compatible with 16-bit executables. Migration from 16-bit to 32-bit is simplified because of the similarity between VBACCES and ACCES32.

PCI

This directory contains PCI-bus specific programs and information. If you are not using a PCI card, this directory will not be installed.

SOURCE

A utility program is provided with source code you can use to determine allocated resources at run-time from your own programs in DOS.

PCIFind.exe

A utility for DOS and Windows to determine what base addresses and IRQs are allocated to installed PCI cards. This program runs two versions, depending on the operating system. Windows 95/98/NT displays a GUI interface, and modifies the registry. When run from DOS or Windows3.x, a text interface is used. For information about the format of the registry key, consult the card-specific samples provided with the hardware. In Windows NT, NTioPCI.SYS runs each time the computer is booted, thereby refreshing the registry as PCI hardware is added or removed. In Windows 95/98/NT PCIFind.EXE places itself in the boot-sequence of the OS to refresh the registry on each power-up.

This program also provides some COM configuration when used with PCI COM ports. Specifically, it will configure compatible COM cards for IRQ sharing and multiple port issues.

WIN32IRQ

This directory provides a generic interface for IRQ handling in Windows 95/98/NT. Source code is provided for the driver, greatly simplifying the creation of custom drivers for specific needs. Samples are provided to demonstrate the use of the generic driver. Note that the use of IRQs in near-real-time data acquisition programs requires multi-threaded application programming techniques and must be considered an intermediate to advanced programming topic. Delphi, C++ Builder, and Visual C++ samples are provided.

Findbase.exe

DOS utility to determine an available base address for ISA bus , non-Plug-n-Play cards. Run this program once, before the hardware is installed in the computer, to determine an available address to give the card. Once the address has been determined, run the setup program provided with the hardware to see instructions on setting the address switch and various option selections.

Poly.exe

A generic utility to convert a table of data into an nth order polynomial. Useful for calculating linearization polynomial coefficients for thermocouples and other non-linear sensors.

Risc.bat

A batch file demonstrating the command line parameters of RISCTerm.exe.

RISCTerm.exe

A dumb-terminal type communication program designed for RS422/485 operation. Used primarily with Remote Data Acquisition Pods and our RS422/485 serial communication product line. Can be used to say hello to an installed modem. RISCTerm stands for Really Incredibly Simple Communications TERMinal.

Getting Started

To begin working with the pod, you first need an available working serial communications port on your PC. This can be either one of our RS422/485 Serial Communication cards or an existing RS-232 port with a 232/485 two-wire converter attached. Next, install the software from the 3½" diskette (RDAG12-8 Software Package). You should also run the RDAG12-8 setup program (which is on the 3½" diskette) to help you with option selection.

1. Verify that you are able to communicate through the COM port (see details in the appropriate COM card manual). View Control Panel | Ports (NT 4) or Control Panel | System | Device Manager | Ports | Properties | Resources (9x/NT 2000) for information about installed COM ports. Communication verification can be done by using a loop-back connector with the card in full-duplex RS-422 mode.

A working knowledge of serial ports in Windows will significantly contribute to your success. You may have built-in COM ports 1 & 2 on your Motherboard, but the software necessary to support them may not be installed in your system. From the Control Panel you may need to “add new hardware” and select standard serial communication port to add a COM port to your system. You may also need to check in the BIOS to ensure that the two standard serial ports are enabled.

We provide two terminal programs to aid with this task. RISCTerm is a DOS-based terminal program, which can also be used in Windows 3.x and 9x. For Windows 9x/NT 4/NT 2000, you can use our WinRISC program. You can select the COM port number (COM5, COM8, etc.), baud, data bits, parity, and stop bits. ACCES Pods ship at 9600, 7, E, 1, respectively. The simplest test to see if you have a good COM port without connecting anything to the COM Port connector on the back of your computer is to select either COM 1 or COM 2 (whichever one is showing up in your device manager) from WinRISC (See “**Running WinRISC**”) then clicking on “Connect”. If you don’t get an error, that is a very good sign that you’re in business. Click the checkbox called “local echo”, then click into the text window, where you should see the blinking cursor, and start typing. If you’ve succeeded in getting to the last step, you’re ready to connect the hardware and attempt to communicate with it.

RDAG12-8 Manual

2. After you have verified that you are able to communicate through your COM port, set up your COM card for half-duplex, RS-485, and wire it up using two wires to the Pod. (You may need to move some jumpers on the COM board to accomplish this. Or if you're using our RS-232/485 Converter, please connect it at this time. Communication with the Pod should be two-wire RS-485, Half-Duplex with Termination and Bias applied. Also select No Echo (where Echo exists) on the COM card. See your manual for the COM card for further details.) You also have to wire appropriate power to the Pod terminals. See the Screw Terminal Pin assignments for help with this. For best results, you'll need +12V and a return to power the pod in the non-isolated mode. For bench testing and setup with one power supply, you'll need to install wire jumpers between the following terminals on the terminal block: ISOV+ to PWR+, and ISOGND to GND. This defeats the optical isolation feature of the Pod, but eases the development setup and only requires one power supply. You should also check the processor board as described in Option Selection to ensure the jumpers JP2, JP3 and JP4 are in the /ISO position.
3. Verify your wiring, then turn on power to the Pod. If you're checking, the current draw should be approximately 250mA.
4. Now you can again run the setup and calibration program(DOS, Win3.x/9x). This time the setup program should auto-detect the Pod from the auto-detect menu item, and allow you to run the calibration routine. If you're using Windows NT, you can run the setup program to set the jumpers regarding isolated or non-isolated communication. To run the calibration routine, just use a DOS boot disk, then run the program. We can provide this if necessary.

Running WinRISC

1. For Windows 9x/NT 4/NT 2000, start the WinRISC program, which should be accessible from the start menu (Start | Programs | RDAG12-8 | WinRISC). If you can't find it, go to Start | Find | Files or Folders and search for WinRISC. You can also explore the CD and look for disks\tools.win\Win32\WinRISC.exe.
2. Once you're in WinRISC, select a baud rate of 9600 (factory default for the Pod). Select Local Echo and the following other settings: Parity-Even, Data Bits-7, Stop Bits-1. Leave other settings at the default. Select the verified COM port (top left) and click on "Connect".
3. Click into the main box. You should see a blinking cursor.
4. Type a few characters. You should see them print to the screen.
5. Proceed to the section "**TALKING TO THE POD**".

Running RISCterm

1. For Win 95/98, run the program RISCterm.exe found in Start | Programs | RDAG12-8. For DOS or Win 3.x, look in C:\RDAG12-8.

2. Enter the base address of the COM card, then enter the IRQ. In Windows, this information is available by viewing the ControlPanel | System | DeviceManager | Ports | Properties | Resources.
3. Once you're in RISCTerm, verify a selection of 9600 baud (factory default for the Pod). The bar across the bottom of the screen should say 7E1.
4. Type a few letter characters. You should see them print to the screen.
5. Proceed to the section, "**TALKING TO THE POD**".

Talking to the Pod

1. (Picking up from step 5 of "**RUNNING WINRISC**" or "**RUNNING RISCTERM**") Press the Enter key a few times. You should receive, "Error, use ? for command list, unrecognized command." This is your first indication that you're talking to the Pod. Repeatedly pressing the Enter key should return this message each time. This is a correct indication.
2. Type "?" and press enter. You should receive back "Main Help Screen" and three possible other menus to access. You could type "?3" then press Enter, and receive a menu back from the Pod regarding Analog Output Commands. If you're receiving these messages, you again know that you are communicating effectively with the Pod.
3. Connect a DMM, set for 20VDC range, across pins 1 (+) and 2 (-) of the Pod's screw terminal block. Type "AC0=0000,00,00,01,0000" and [Enter]. You should receive a CR (carriage return) from the Pod. This command sets Channel 0 for the 0-10V range.
4. Now type "A0=FFF0" and [Enter]. You should receive a carriage return from the Pod. This command causes Channel 0 to output the commanded value (FFF in hex = 4096 counts, or 12-bit, Full Scale). You should see the DMM read 10VDC. Calibration is discussed in the following section.
5. Type "A0=8000" and [Enter] (800 in hex = 2048 counts, or 12-bit, Half Scale). You should receive a carriage return from the Pod. You should see the DMM read 5VDC.
6. You're now ready to begin your development and write your application program.

Note: If you're ultimately going to use the "Isolated Mode", be sure that you put the jumpers on the processor board back to the "ISO" positions. Also ensure that you wire the power up correctly to support that mode. It requires 12V of local power, and 12V of isolated power. Isolated Power can be supplied from the computer's power supply, or some other central supply. Current draw on this source is negligible, so voltage drop in the cable is of no consequence. Be aware that the High Power Pod version (RDAG12-8H) requires +12V, Gnd, and -12V for "Local Power".

Calibration

The setup software provided with the RDAG12-8 and RDAG12-8H supports the ability to check calibration and to write correction values into EEPROM so they are available automatically on power-up. Calibration checks need only be performed periodically, not every time power is cycled.

RDAG12-8 Manual

The SETUP.EXE software calibration procedure can be used to calibrate all three ranges and store the values in the EEPROM. For Windows NT, you'll need to boot to DOS to run this program. You can create a DOS boot disk from any Windows system not running NT. We can provide a DOS boot disk if necessary.

The SAMPLE1 program illustrates the procedure of recalling these values and adjusting the readings. The description of the CALn? command shows the order in which the information is stored in the EEPROM.

Installation

The RDAG12-8 enclosure is a sealed, die-cast, aluminum-alloy, NEMA-4 enclosure that is easily mounted. Outside dimensions of the enclosure are: 8.75" long by 5.75" wide by 2.25" high. The cover incorporates a recessed neoprene gasket and the cover is secured to the body by four recessed M-4, stainless steel, captive screws. Two long M-3.5 X 0.236 screws are provided for mounting to the body. Mounting holes and cover-attaching screws are outside the sealed area to prevent ingress of moisture and dust. Four threaded bosses inside the enclosure provide for mounting the printed circuit card assemblies. To install the card without the box in your own enclosure, see Figure 1-2 for the hole spacing.

The RDAG12-8H enclosure is a non-sealed steel enclosure painted "IBM Industrial Gray". The enclosure measures 8.5" long by 5.25" wide by 2" high.

There are three jumper locations on the unit and their functions are as follows:

JP2, JP3, and JP4: Normally these jumpers should be in the "ISL" position. If you wish to by-pass the opto-isolators, then you can move these jumpers to the "/ISL" position.

Input/Output Pin Connections

Electrical connections to the RDAG12-8 are through a watertight gland that seals the wires and are terminated inside to a Euro style, screw-terminal block that plugs into a 50-pin connector. Electrical connections to the RDAG12-8H are through openings on the end of the T-Box, terminated in the same Euro style, screw-terminal block. Connector pin assignments for the 50-pin connector follow:

Pin	Signal	Pin	Signal
1	VOUT0 (Analog Volt. Output 0)	2	APG0 (Analog Power Ground 0)
3	VOUT1 (Analog Volt. Output 1)	4	APG1 (Analog Power Ground 1)
5	VOUT2 (Analog Volt. Output 2)	6	APG2 (Analog Power Ground 2)
7	GND (Local Power Ground)	8	DIO6 (Digital Input/Output 6)
9	DIO5 (Digital Input/Output 5)	10	DIO4 (Digital Input/Output 4)
11	DIO3 (Digital Input/Output 3)	12	DIO2 (Digital Input/Output 2)
13	DIO1 (Digital Input/Output 1)	14	DIO0 (Digital Input/Output 0)
15	GND (Local Power Ground)	16	APG3 (Analog Power Ground 3)
17	VOUT3 (Analog Volt. Output 3)	18	IOUT0 (Analog Current Output 0)
19	IOUT1 (Analog Current Output 1)	20	IOUT2 (Analog Current Output 2)
21	IOUT3 (Analog Current Output 3)	22	AOGND (Analog Output Ground)
23	IOUT4 (Analog Current Output 4)	24	IOUT5 (Analog Current Output 5)
25	IOUT6 (Analog Current Output 6)	26	IOUT7 (Analog Current Output 7)
27	AOGND (Analog Output Ground)	28	APG4 (Analog Power Ground 4)
29	VOUT4 (Analog Volt. Output 4)	30	AOGND (Analog Output Ground)
31	GND (Local Power Ground)	32	/PINT1 (Protected Interr. Input 1)
33	/PINT0 (Protected Interr. Input 0)	34	/PT0 (Protected Tmr./Ctr. Input)
35	PWR+ (Local Power Supply +)	36	PWR+ (Local Power Supply +)
37	GND (Local Power Ground)	38	APG5 (Analog Power Ground 5)
39	VOUT5 (Analog Volt. Output 5)	40	PWR- (Local Power Supply -)
41	/PBRST (Pushbutton Reset)	42	ISOGND (Isol. Power Supply)
43	ISOV+ (Isol. Power Supply +)	44	RS485+ (Communication Port +)
45	/RS485- (Communication Port -)	46	APG6 (Analog Power Ground 6)
47	VOUT6 (Analog Volt. Output 6)	48	APPLV+ (Application Power Ground 7)
49	VOUT7 (Analog Volt. Output 7)	50	APG7 (Analog Power Ground 7)

Table 2-1: 50 Pin Connector Assignments

Terminal markings and their functions are as follows:

PWR+ and GND: (Pins 7, 15, 31, 35, and 37) These terminals are used to apply local power to the Pod from a local power supply. (Pins 35 and 36 are tied together.) The voltage can be anywhere in the range of 12 VDC to 16 VDC. Higher voltage can be used, 24 VDC for example, if an external Zener diode is used to reduce the voltage applied to the RDAG12-8. (See the Specification section of this manual to determine the Zener diode power rating required.)

PWR- (Pin 40) This terminal accepts customer supplied -12V to 18 VDC @ 2A max. It is used only in the High Power option RDAG12-8H.

RDAG12-8 Manual

ISOV+ and ISOGND: This is the power connection for the isolator section that may be supplied from the computer's +12VDC supply via a pair of wires on the RS-485 network or from a central power supply. This power is independent of "local power". The voltage level can be from 7.5 VDC to 35 VDC. (An on-board voltage regulator regulates the power to +5 VDC.) RDAG12-8 will require only about 5 mA of current when idling and ~33mA current when data is being transmitted so any loading effects on the computer power (if used) will be low.

Note

If separate power is not available, ISOV+ and ISOGND must be jumpered to the "local power" terminals, which defeats the optical isolation.

RS485+ and RS485-: These are the terminals for RS485 communications (TRx+ and TRx-).

APPLV+: This terminal is for the "application power" or the user provided voltage source to which digital outputs are connected through the loads. Open-collector Darlington amplifiers are used at the outputs. Inductive suppression diodes are included in the APPLV+ circuit. The application power level (APPLV+) can be as high as 50 VDC.

APG0-7: These terminals are for use with the High Power version of the Pod (RDAG12-8H). Connect all load returns to these terminals.

AOGND: These terminals are for use with the Low Power version of the Pod. Use these for returns of voltage outputs as well as current outputs.

GND: These are general purpose grounds which can be used for Digital Bit returns, Power return connections, and so on.

To ensure that there is minimum susceptibility to EMI and minimum radiation, it is important that there be a positive chassis ground. Also, proper EMI cabling techniques (cable connected to chassis ground, twisted pair wiring, and, in extreme cases, ferrite-level of EMI protection) may be needed for input/output wiring.

VOU0-7: Analog Output Voltage signal, use in conjunction with AOGND

IOUT0-7: 4-20mA Current Sink Output signal, use in conjunction with an external power supply (5.5V to 30V).

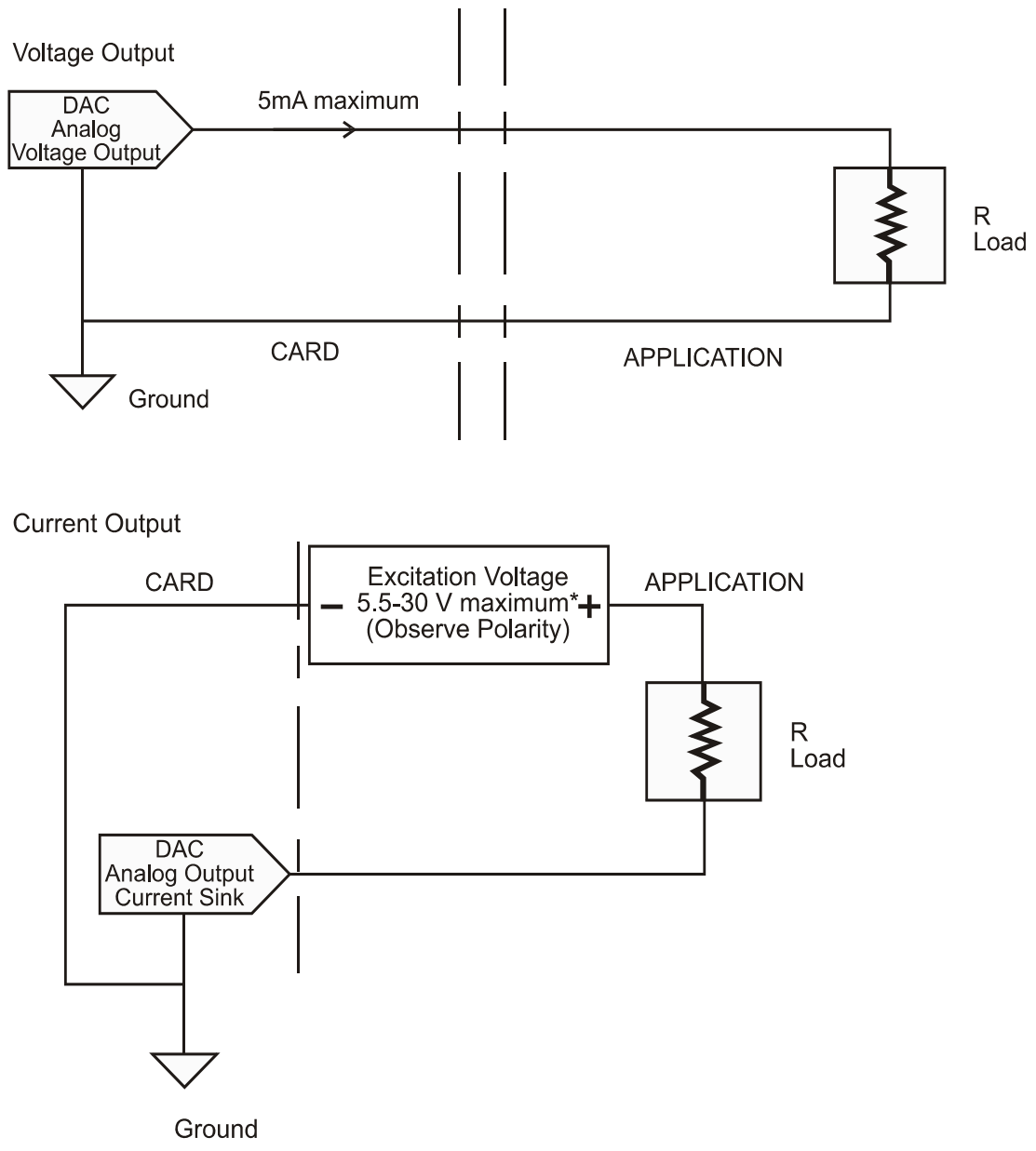

Figure 2-1: Simplified Schematic for Voltage and Current Sink Outputs

Chapter 3: Software

General

The RDAG12-8 comes with ASCII-based software provided on CD. ASCII programming permits you to write applications in any high-level language that supports ASCII text string functions, allowing the "REMOTE ACCES" series modules to be used with virtually any computer that has an RS485 port.

The communication protocol has two forms: addressed and non-addressed. Non-addressed protocol is used when only one REMOTE ACCES Pod is to be used. Addressed protocol must be used when more than one REMOTE ACCES Pod is to be used. The difference is that an address command is sent to enable the specific Pod. The address command is only sent once during communication between the specific Pod and the host computer. It enables communication with that specific Pod and disables all other REMOTE ACCES devices on the network.

Command Structure

All communication must be 7 data bits, even parity, 1 stop bit. All numbers sent to and received from the Pod are in hexadecimal form. The factory default baud rate is 9600 Baud. The Pod is considered to be in addressed mode any time its Pod address is not 00. The factory default Pod address is 00 (non-addressed mode).

Addressed Mode

The address select command must be issued before any other command to the addressed Pod. The address command is as follows:

"!xx[CR]" where xx is the Pod address from 01 to FF hex, and [CR] is Carriage Return, ASCII character 13.

The Pod responds with "[CR]". Once the address select command has been issued, all further commands (other than a new address select) will be executed by the selected Pod. *The addressed mode is required when using more than one Pod.* When there's only one Pod connected, no address select command is needed.

You can merely issue commands listed in the following table. Terminology used is as follows:

- a. The single lower case letter 'x' designates any valid hex digit (0-F).
- b. The single lower case letter 'b' designates either a '1' or '0'.
- c. The symbol '±' designates either a '+' or a '-'.
- d. All commands are terminated with [CR], the ASCII character 13.
- e. All commands are not case-sensitive, i.e., upper or lower case may be used.
- f. The symbol '*' means zero or more valid characters (total msg length<255 decimal).

General Note: ALL numbers passed to and from the Pod are in hexadecimal.

RDAG12-8 Manual

Command	Description	Returns
An=xxx0	Write xxx0 to DAC n If the letter A is sent in place of n, all DACs are affected	[CR]
An,iiii=xxx0	Write xxx0 to DAC n buffer entry [iiii]	[CR]
An=GOGOGO	Write buffer to DAC n at Timebase rate	[CR]
An=STOP	Cease writing DAC n buffer to DAC	[CR]
S=xxxx or S?	Set or read acquisition rate (00A3 <= xxxx <= FFFF)	(xxxx)[CR]
ACn=xxx0,dd,tt,mm,iiii	Configure Analog Outputs. See body text.	[CR]
BACKUP=BUFFER	Write buffer into EEPROM	[CR]
BUFFER=BACKUP	Read EEPROM into buffer	[CR]
CALn?	Read calibration data for n	bbbb,mmmm[CR]
CAL=BACKUP	Restore factory calibration	[CR]
Caln=xxxx,yyyy	Write calibration values for channel n	[CR]
?	Command reference for RDAG12-8(H)	See Desc.
H	Greeting message	See Desc.
V	Read firmware revision number	n.nn[CR]
N	Resend Pod's last transmission	See Desc.
POD=xx	Assign pod to number xx	-.Pod#xx[CR]
BAUD=nnn	Set communication baud rate (1 <= n <= 7)	=:Baud:0n[CR]
Mxx	Set digital mask to xx, 1 is output, 0 is input	[CR]
Mx+ or Mx-	Set bit x of digital mask to output (+) or input (-)	[CR]
I or In	Read the 7 digital input bits, or bit n	xx[CR] or b[CR]
Oxx	Write byte xx to digital outputs (7 bits are significant)	[CR]
On+ or On-	Turn on or off digital bit n (0 <= n <= 6)	[CR]

Table 3-1: RDAG12-8 Command List

Note

Pod reset occurs upon power-up, programming process, or watchdog time-out.

Command Functions

The following paragraphs give details of the command functions, describe what the commands cause, and give examples. Please note that all commands have an acknowledgement response. You must wait for a response from a command before sending another command.

Write to DAC Channel

$A_n=xxx0$ Writes xxx to DAC n. Set polarity and gain using the AC command.

Example:

Program the Analog output number 4 to half-scale (zero volts bipolar or half scale unipolar)

```
SEND: A4=8000[CR]
RECEIVE: [CR]
```

Load Buffer for DAC n

$A_n,iiii=xxx0$ Writes xxx to DAC n buffer [iiii].

Example:

Program buffer for DAC 1 to a simple stair step

```
SEND: A1,0000=0000[CR]
RECEIVE: [CR]
SEND: A1,0001=8000[CR]
RECEIVE: [CR]
SEND: A1,0002=FFF0[CR]
RECEIVE: [CR]
SEND: A1,0003=8000[CR]
RECEIVE: [CR]
```

Read Buffer from DAC n

$A_n,iii=?$ Reads from buffer ($0 \leq n \leq 7$, $0 \leq iii \leq 800h$).

Example:

Read buffer entry number 2 for DAC 1

```
SEND: A1,0002=?[CR]
RECEIVE: FFF0[CR]
```

Start Buffered DAC Output on DAC n

$A_n=GOGOGO$ Writes buffer to DAC n at a timebase rate.

Example:

Begin Buffer writing on DAC 5

```
SEND: A5=GOGOGO[CR]
```

RDAG12-8 Manual

RECEIVE: [CR]

Stop Buffered DAC Outputs on DAC n

A_n=STOP Ceases writing DAC n buffer to DAC.

Example:

Immediately cease pattern output on DAC 5

SEND: A5=STOP[CR]

RECEIVE: [CR]

Set Acquisition Rate

S=xxxx or s=? Set or read acquisition rate (00A3 <= xxxx <= FFFF).

This function sets the update rate of the DAC. Valid values range from 00A2 to FFFF. The value passed is the desired divisor of the rate clock (11.0592 MHz). The equation to use in calculating the divisor is:

$$\text{Divisor} = [(1/\text{Rate}) - 22\mu\text{Sec}] * [\text{Clock}/12]$$

Example:

Program the RDAG12-8 for 1K samples per second

SEND: S0385[CR]

RECEIVE: [CR]

Note: The sample rate configured is stored in EEPROM on the Pod, and will be used as the default (power-on) sample rate. The factory default sample rate (100Hz) can be restored by sending “S0000” to the Pod.

Configure Buffers and DACs

AC_n=xxx0,dd,tt,mm,iiii

- xxx0 is the desired power-on (initial) state of DAC n
- dd is the divisor for the output rate (00 <= dd <= FF)
- tt is the number of times to run
- mm is the polarity and gain select for DAC n
 - mm = 00 = ±5V
 - mm = 01 = 0-10V
 - mm = 02 = 0-5V
- iiii is the buffer array entry (000 <= iiii <= 800h)

Example:

To configure DAC 3 to: Power on at 8000 counts;
 Use one half the Sxxxx timebase as its buffered output rate;
 Output the Buffer a total of 15 times, then stop;
 Use the ±5V range;
 Output a buffer a total of 800 hex entries long

Use the command:

AC3=8000,02,0F,00,0800[CR]

Set Calibration Parameters

CALn=bbbb,mmmm Write span and offset calibration values in two's-complement hex as two four-digit numbers.

Example:

Write a span of 42h and an offset of 36h to DAC 1

SEND: CAL1=0036,0042[CR]

RECEIVE: [CR]

Read Calibration Parameters

CALn? Recalls the scale and offset calibration constants.

Example:

Read calibration parameters after the above write

SEND: CAL1?[CR]

RECEIVE: 0036,0042[CR]

Store Calibration Parameters

BACKUP=CAL Backup the last calibration

This function stores the values required to adjust the measurement readings to agree with the last calibration. The setup program will measure and write these calibration parameters. The SAMPLE1 program illustrates using the CALn? Command with the results of this function.

Configure Bits as Input or Output

Mxx Configures digital bits as inputs or outputs.

Mx+ Configures digital bit 'x' as output.

Mx- Configures digital bit 'x' as input.

These commands program the digital bits, on a bit-by-bit basis, as input or output. A "zero" in any bit position of the xx control byte designates the corresponding bit to be configured as an input. Conversely, a "one" designates a bit to be configured as an output. (Note: Any bit configured as an output can still be read as an input if the current value output is a "one".)

Examples:

Program even bits as outputs, and odd bits as inputs.

SEND: MAA[CR]

RECEIVE: [CR]

Program bits 0-3 as input, and bits 4-7 as output.

SEND: MF0[CR]

RECEIVE: [CR]

Read Digital Inputs

I Read 7 bits

RDAG12-8 Manual

In Read bit number n

These commands read the digital input bits from the Pod. All byte responses are sent most-significant nibble first.

Examples:

Read ALL 7 bits.

```
SEND:      I[CR]
RECEIVE:   FF[CR]
```

Read only bit 2.

```
SEND:      I2[CR]
RECEIVE:   1[CR]
```

Write Digital Outputs

Oxx Write to all 7 digital output bits. (Port 0)
 Ox± Set bit x hi or low

These commands write outputs to digital bits. Any attempt to write to a bit configured as an input will fail. Writing to a byte or word wherein some bits are input and some are output will cause the output latches to change to the new value, but the bits which are inputs will not output the value until/unless they are placed in output mode. Single bit commands will return an error (4) if an attempt is made to write to a bit configured as an input.

Writing a "one" (+) to a bit asserts the pull-down for that bit. Writing a "zero" (-) de-asserts the pull-down. Therefore, if the factory default +5V pull-up is installed, writing a one will cause zero volts to be at the connector, and writing a zero will cause +5 volts to be asserted.

Examples:

Write a one to bit 6 (set output to zero volts, assert the pull-down).

```
SEND:      O6+[CR]
RECEIVE:   [CR]
```

Write a zero to bit 2 (set output to +5V or user pull-up).

```
SEND:      O2-[CR]
or
SEND:      O02-[CR]
RECEIVE:   [CR]
```

Write zeros to bits 0-7.

```
SEND:      O00[CR]
RECEIVE:   [CR]
```

Write zeros to every odd bit.

```
SEND:      OAA[CR]
RECEIVE:   [CR]
```

Read Firmware Revision Number

V: Read the firmware revision number

This command is used to read the version of firmware installed in the Pod. It returns "X.XX[CR]".

Example:

Read the RDAG12-8 version number.

```
SEND:      V[CR]
RECEIVE:   1.00[CR]
```

Note

The "H" command returns the version number along with other information. See "Hello Message" following.

Resend Last Response

n Resend last response

This command will cause the Pod to return the same thing it just sent. This command works for all responses less than 255 characters in length. Normally this command is used if the host detected a parity or other line fault while receiving data, and needs the data to be sent a second time.

The "n" command may be repeated.

Example:

Assuming the last command was "I", ask Pod to resend last response.

```
SEND:      n
RECEIVE:   FF[CR] ;or whatever the data was
```

Hello Message

H* Hello message

Any string of characters starting with "H" will be interpreted as this command. ("H[CR]" alone is also acceptable.) The return from this command takes the form (without the quotes):

```
"=Pod aa, RDAG12-8 Rev rr Firmware Ver:x.xx ACCES I/O Products, Inc."
```

aa is the Pod address

rr is the hardware revision, such as "B1"

x.xx is the software revision, such as "1.00"

Example:

Read the greeting message.

```
SEND:      Hello?[CR]
RECEIVE:   Pod 00, RDAG12-8 Rev B1 Firmware Ver:1.00 ACCES I/O Products,
           Inc.[CR]
```

RDAG12-8 Manual

Configure Baud Rate (When Shipped by Acces, the Baud Rate Is Set at 9600.)

BAUD=nnn Program the Pod with a new baud rate

This command sets the Pod to communicate at a new baud rate. The parameter passed, nnn, is slightly unusual. Each n is the same digit from the following table:

Code	Baud Rate
0	1200
1	2400
2	4800
3	9600
4	14400
5	19200
6	28800
7	57600

Therefore, valid values for the command's "nnn" are 000, 111, 222, 333, 444, 555, 666, or 777. The Pod returns a message indicating it will comply. The message is sent in the old baud rate, not the new one. Once the message is transmitted, the Pod changes to the new baud rate. The new baud rate is stored in EEPROM and will be used even after power-reset, until the next "BAUD=nnn" command is issued.

Example:

Set the Pod to 19200 baud.

SEND: BAUD=555[CR]

RECEIVE: Baud:05[CR]

Set the Pod to 9600 baud.

SEND: BAUD=333[CR]

RECEIVE: Baud:03[CR]

Configure Pod Address

POD=xx Program the currently selected Pod to respond at address xx.

This command changes the Pod's address to xx. If the new address is 00, the Pod will be placed into non-addressed mode. If the new address is not 00, the Pod will not respond to further communications until a valid address command is issued. Hex numbers 00-FF are considered valid addresses. The RS485 specification allows only 32 drops on the line, so some addresses may be unused.

The new Pod address is saved in EEPROM and will be used even after power-down until the next "Pod=xx" command is issued. Note that, if the new address is not 00 (i.e., the Pod is configured to be in addressed mode), it is necessary to issue an address command to the Pod at the new address before it will respond.

The Pod returns a message containing the Pod number as confirmation.

Example:

Set the Pod address to 01.

```
SEND:      Pod=01[CR]
RECEIVE:   =:Pod#01[CR]
```

Set the Pod address to F3.

```
SEND:      Pod=F3[CR]
RECEIVE:   =:Pod#F3[CR]
```

Take the Pod out of addressed mode.

```
SEND:      Pod=00[CR]
RECEIVE:   =:Pod#00[CR]
```

Address Select

```
!xx                Selects the Pod addressed 'xx'
```

Note

When using more than one Pod in a system, each Pod is configured with a unique address. This command must be issued prior to any other commands to that particular Pod. This command needs to be issued only once prior to executing any other commands. Once the address select command has been issued, that Pod will respond to all other commands until a new address select command is issued.

Error Codes

The following error codes can be returned from the Pod:

- 1: Invalid channel number (too large, or not a number. All channel numbers must be between 00 and 07).
- 3: Improper Syntax. (Not enough parameters is the usual culprit).
- 4: Channel number is invalid for this task (For example if you try to output to a bit that is set as an input bit, that will cause this error).
- 9: Parity error. (This occurs when some part of the received data contains a parity or framing error).

Additionally, several full-text error codes are returned. All begin with "Error, " and are useful when using a terminal to program the Pod.

```
Error, Unrecognized Command: {command received}[CR]
This occurs if the command is not recognized.
```

```
Error, Command not fully recognized: {Command received}[CR]
This occurs if the first letter of the command is valid, but the remaining letters are not.
```

RDAG12-8 Manual

Error, Address command must be CR terminated[CR]

This occurs if the address command (!xx[CR]) has extra characters between the Pod number and the [CR].

Appendix A: Application Considerations

Introduction

Working with RS422 and RS485 devices is not much different from working with standard RS232 serial devices and these two standards overcome deficiencies in the RS232 standard. First, the cable length between two RS232 devices must be short; less than 50 feet at 9600 baud. Second, many RS232 errors are the result of noise induced on the cables. The RS422 standard permits cable lengths up to 4000 feet and, because it operates in the differential mode, it is more immune to induced noise.

Connections between two RS422 devices (with CTS ignored) should be as follows:

Device #1		Device #2	
Signal	Pin No.	Signal	Pin No.
Gnd	7	Gnd	7
TX ⁺	24	RX ⁺	12
TX ⁻	25	RX ⁻	13
RX ⁺	12	TX ⁺	24
RX ⁻	13	TX ⁻	25

Table A-1: Connections Between Two RS422 Devices

A third deficiency of RS232 is that more than two devices cannot share the same cable. This is also true for RS422 but RS485 offers all the benefits of RS422 plus allows up to 32 devices to share the same twisted pairs. An exception to the foregoing is that multiple RS422 devices can share a single cable if only one will talk and the others will all receive.

Balanced Differential Signals

The reason that RS422 and RS485 devices can drive longer lines with more noise immunity than RS232 devices is that a balanced differential drive method is used. In a balanced differential system, the voltage produced by the driver appears across a pair of wires. A balanced line driver will produce a differential voltage from ± 2 to ± 6 volts across its output terminals. A balanced line driver can also have an input "enable" signal that connects the driver to its output terminals. If the "enable" signal is OFF, the driver is disconnected from the transmission line. This disconnected or disabled condition is usually referred to as the "tristate" condition and represents a high impedance. RS485 drivers must have this control capability. RS422 drivers may have this control but it is not always required.

RDAG12-8 Manual

A balanced differential line receiver senses the voltage state of the transmission line across the two signal input lines. If the differential input voltage is greater than +200 mV, the receiver will provide a specific logic state on its output. If the differential voltage input is less than -200 mV, the receiver will provide the opposite logic state on its output. A maximum operating voltage range is from +6V to -6V allows for voltage attenuation that can occur on long transmission cables.

A maximum common mode voltage rating of $\pm 7V$ provides good noise immunity from voltages induced on the twisted pair lines. The signal ground line connection is necessary in order to keep the common mode voltage within that range. The circuit may operate without the ground connection but may not be reliable.

Parameter	Conditions	Min.	Max.
Driver Output Voltage (unloaded)		4V	6V
		-4V	-6V
Driver Output Voltage (loaded)	LD and LDGND	2V	
	jumpers in	-2V	
Driver Output Resistance			50 Ω
Driver Output Short-Circuit Current			± 150 mA
Driver Output Rise Time			10% unit interval
Receiver Sensitivity			± 200 mV
Receiver Common Mode Voltage Range			$\pm 7V$
Receiver Input Resistance			4K Ω

Table A-2: RS422 Specification Summary

To prevent signal reflections in the cable and to improve noise rejection in both the RS422 and RS485 mode, the receiver end of the cable should be terminated with a resistance equal to the characteristic impedance of the cable. (An exception to this is the case where the line is driven by an RS422 driver that is never "tri-stated" or disconnected from the line. In this case, the driver provides a low internal impedance that terminates the line at that end.)

RS485 Data Transmission

The RS485 Standard allows a balanced transmission line to be shared in a party-line mode. As many as 32 driver/receiver pairs can share a two-wire party line network. Many characteristics of the drivers and receivers are the same as in the RS422 Standard. One difference is that the common mode voltage limit is extended and is +12V to -7V. Since any driver can be disconnected (or tri-stated) from the line, it must withstand this common mode voltage range while in the tristate condition.

The following illustration shows a typical multidrop or party line network. Note that the transmission line is terminated on both ends of the line but not at drop points in the middle of the line.

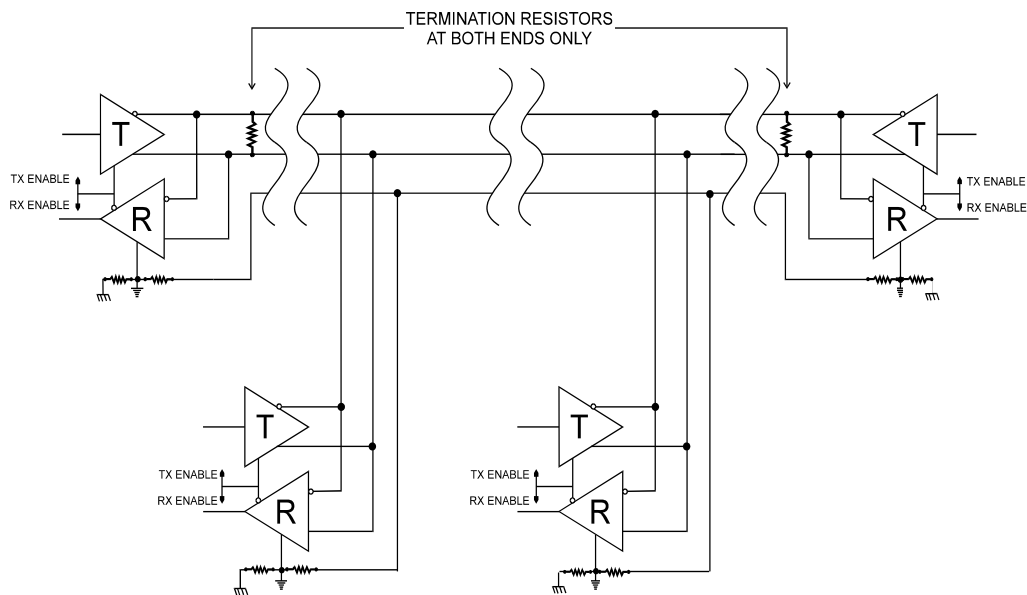

Figure A-1: Typical RS485 Two-Wire Multidrop Network

RDAG12-8 Manual

Appendix B: Thermal Considerations

The low power version of the RDAG12-8 ships installed in a NEMA- 4 box, 8.75" long by 5.75" wide by 2.25" high. The box has two round openings with a rubber glands for routing and sealing the I/O cables. When all 8 output channels are loaded with a 10mA load @5Vdc the power dissipation of the RDAG12-8 is 5.8W. The thermal resistance of the box with an installed RDAG12-8 card is 4.44°C/W. At $T_{\text{ambient}} = 25^{\circ}\text{C}$ the temperature inside the box is 47.75°C. The allowed temperature rise inside the box is $70 - 47.75 = 22.25^{\circ}\text{C}$. Thus the maximum ambient operating temperature is $25 + 22.25 = 47.5^{\circ}\text{C}$.

The RDAG12-8 high power version can be packaged in several ways:

- a) In the T-box (8.5"x5.25"x2") with a 4.5"x.5" slot for cable routing and air circulation.
- b) In an open enclosure exposed to free air.
- c) In free air with air circulation provided by the customer..

When the high power option is elected, special attention must be paid to heat generation and heat sinking. The output amplifiers are capable of delivering 3A at output voltage ranges 0-10V, +/-5V, 0-5V. However the capability to dissipate the heat generated in the amplifiers limits the permissible load current. This capability is determined in a significant degree by the type of enclosure the RDAG12-8 is packaged in.

When installed in the T-box the total power dissipation can be estimated using the following calculations:

The power dissipated in the output amplifier for each channel is:

$$P_{da} = (V_s - V_{out}) \times I_{Load}$$

Where :

P _{da}	Power dissipated in the output power amplifier
V _s	Power supply voltage
I _{load}	Load current
V _{out}	Output voltage

Thus if the power supply voltage $V_s = 12\text{v}$, the output voltage range is 0-5V and the load is 400ohms, the power dissipated in the output amplifier by the load current is $7\text{V} \times .125\text{A} = .875\text{W}$. The power dissipated by the quiescent current $I_o = .016\text{A}$. $P_o = 24\text{V} \times .016\text{A} = .4\text{w}$. Thus the total power dissipated in the amplifier is 1.275W. In the idle mode of operation (the outputs not loaded) at 25 °C ambient air temperature the temperature inside the box (in the proximity of the power amplifiers) is ~45°C. The power dissipation in the idle mode is 6.7W.

The thermal resistance of the box R_{thenc1} (measured in the proximity of the power amplifiers) is estimated to be ~2°C/W. Thus the allowed output power for a maximum temperature inside the enclosure 70°C is $25^{\circ}\text{C} / 2^{\circ}\text{C}/\text{w} = 12.5\text{W}$ at 25°C ambient air temperature. Thus the allowed total power dissipation with outputs driving resistive loads is ~19.2W at 25°C ambient temperature.

Derating for the ambient temperature rise is $1/R_{\text{thenc1}} = .5\text{W}$ for each degreeC of ambient temperature rise.

Operation In Free Air

RDAG12-8 Manual

The heatsink temperature of the amplifier supplying .250A at 5V DC can reach 100°C. max (measured at ambient room temperature of 25°C). The power dissipated by the amplifier is $(12-5) \times .250 = 1.750W$. The maximum allowed junction temperature is 125°C. Assuming the junction-to-case and case-to-heat sink surface thermal resistance for the TO-220 package is 3°C/W and 1°C/W respectively. The junction-to-heat sink resistance $R_{JHS}=4°C/W$. The temperature rise between the heat sink surface and the junction is $4°C/W \times 1.75W=7°C$. Thus the allowed maximum temperature of the heat sink is $125-107=18°C$. Therefore if any of the channels of the RDAG12-8 has a 250mA load the ambient temperature rise is limited to 18°C. The allowable maximum ambient temperature will be $25 + 18=43°C$.

If forced air cooling is provided then the following calculation will determine the allowable load for the RDAG12-8 allowable power dissipation for the power amplifier:

$$P_{max} = (125°C - T_{amb,max}) / (R_{HS} + R_{JHS}) \quad \text{where}$$

Heatsink thermal resistance R_{HS}	= 21°C/W
Junction- to-heatsink surface thermal resistance R_{JHS}	= 4 °C/W
Operating temperature range	= 0 - 50°C
Maximum ambient temperature $T_{amb,max}$	= 50°C

At air velocity of <100 ft/min	$P_{max} = 3W$	
At air velocity of 100 ft/min	$P_{max} = 5W$	(As determined by the heat sink characteristics)

Customer Comments

If you experience any problems with this manual or just want to give us some feedback, please email us at: manuals@accessioproducts.com. Please detail any errors you find and include your mailing address so that we can send you any manual updates.



10623 Roselle Street, San Diego CA 92121
Tel. (858)550-9559 FAX (858)550-7322
www.accessioproducts.com

Assured Systems

Assured Systems is a leading technology company with over 1,500 regular clients in 80 countries, deploying over 85,000 systems to a diverse customer base in 12 years of business. We offer high-quality and innovative rugged computing, display, networking and data collection solutions to the embedded, industrial, and digital-out-of-home market sectors.

US

sales@assured-systems.com

Sales: +1 347 719 4508
Support: +1 347 719 4508

1309 Coffeen Ave
Ste 1200
Sheridan
WY 82801
USA

EMEA

sales@assured-systems.com

Sales: +44 (0)1785 879 050
Support: +44 (0)1785 879 050

Unit A5 Douglas Park
Stone Business Park
Stone
ST15 0YJ
United Kingdom

VAT Number: 120 9546 28
Business Registration Number: 07699660