

# 10.1" P-Cap Chassis Display - W10L100-PCH1-PoE

## Features

- 10.1" 1024 x 600 Resolution
- Projected Capacitive Multi-Touch (P-Cap)
- Front IP65 Water and Dust Proof
- VGA input and variety of optional connectors
- USB port for touch
- Stylish and elegant design
- Supports PoE

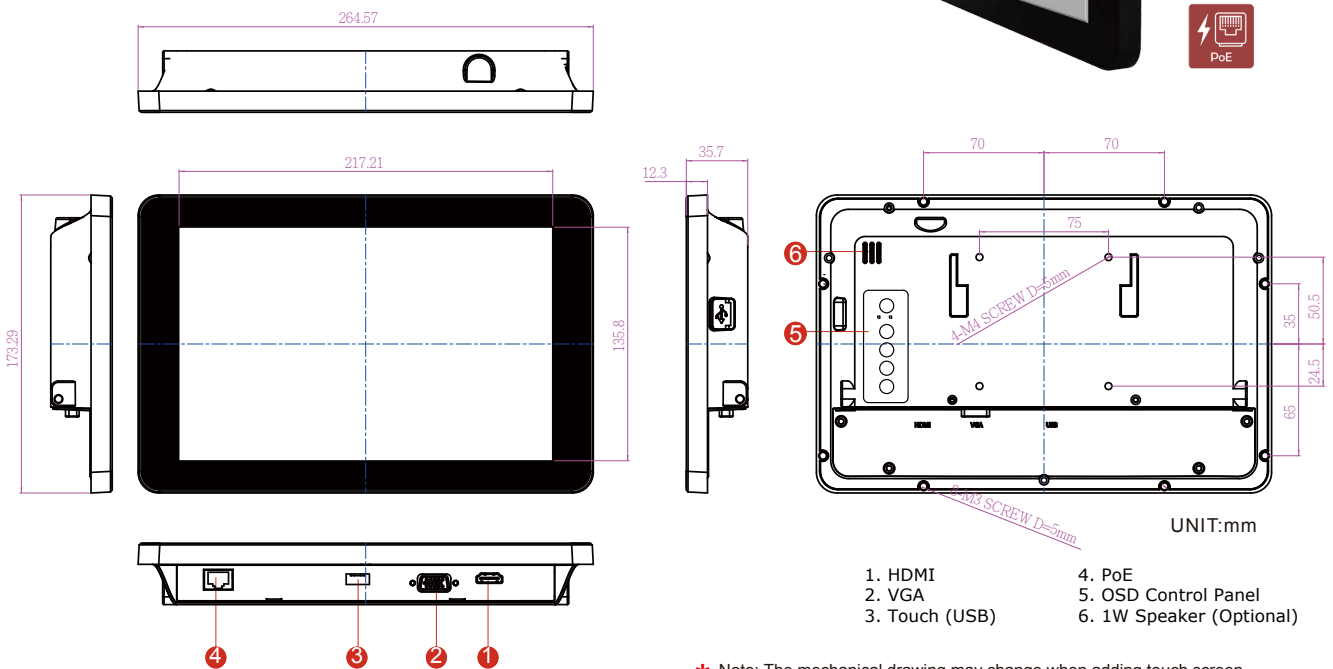

\* Note: The mechanical drawing may change when adding touch screen. Please contact our sales representative if you need further product information.

## Specifications

### Display

- Panel Size : 10.1"
- Active Display Area(mm) : 222.72 (H) x 125.28 (V)
- Resolution : 1024 x 600
- Brightness(cd/m2) : 420 (Typical)
- Contrast Ratio : 800:1 (Typical)
- Viewing Angles(CR>=10 L/R/U/D) : -80~80(H) ; -80~75(V)
- Display Colors : 16.7M (8 bits/color)
- Standard Input Signal : 1 x VGA (D-sub 15)  
1 x HDMI (Type-A)

### Power Considerations

- Power Input/Power Over Ethernet : Power Device (PD) follows IEEE 802.3at (25 W), IEEE 802.3af (15 W)
- Power Consumption : 10W typical , Normal operation

### Environment

- Operating temperature : 0~50°C
- Storage Temperature : -10~60°C
- IP Rating : Front IP65
- Certifications : CE, FCC

### Output

- Touch Screen : Projected Capacitive Touch (USB)
- Speakers (Optional) : 1 x Speaker
- OSD : 5 Keys: -, +, Power, Esc, Enter

### Accessories

- Accessories : VGA cable (1.8m)  
HDMI cable (2m)

\*Outside dimension and I/O will be different from standard

## Assured Systems

Assured Systems is a leading technology company with over 1,500 regular clients in 80 countries, deploying over 85,000 systems to a diverse customer base in 12 years of business. We offer high-quality and innovative rugged computing, display, networking and data collection solutions to the embedded, industrial, and digital-out-of-home market sectors.

### US

[sales@assured-systems.com](mailto:sales@assured-systems.com)

Sales: +1 347 719 4508  
Support: +1 347 719 4508

1309 Coffeen Ave  
Ste 1200  
Sheridan  
WY 82801  
USA

### EMEA

[sales@assured-systems.com](mailto:sales@assured-systems.com)

Sales: +44 (0)1785 879 050  
Support: +44 (0)1785 879 050

Unit A5 Douglas Park  
Stone Business Park  
Stone  
ST15 0YJ  
United Kingdom

VAT Number: 120 9546 28  
Business Registration Number: 07699660