

CS-W115FHC/P2102

15.6" TFT-LCD Sunlight Readable and Modular Panel PC with 8th Gen. Intel® Core™ U Series Processor



- 15.6" TFT-LCD with Ultra-high Brightness up to 1,500 nits and 1920 x 1080 Resolution
- Onboard 8th Generation Intel® Core™ U Series Processor
- 2x DDR4 SO-DIMM Socket, Supports Up to 2400MHz, 64GB
- Supports Triple Independent Display
- Integrated USB 3.2 Gen 2 supports up to 10Gbps
- M.2 E Key Socket for Wireless Module or Intel CRF Module
- Supports Ignition Sensing Function (IGN) (with optional CFM module)
- Supports 2x PoE+ Function (with optional CFM module)
- Wide Range Operating Temperature -10°C to 70°C
- Designed with Rugged Aluminum Die-casting Front Bezel
- True Flat IP65 Compliant Front Panel Protection
- Supports Panel / VESA / Rack Mounting

Overview

The CS-W115FHC/P2102 is a 15.6" TFT-LCD sunlight readable panel PC that offers sufficient screen brightness for better image quality in outdoor usage. The panel PC is powered by Intel® 8th generation Core™ U series processor that brings outstanding computing performance boost up to 84% at a TDP of 15 watts, compared to 6th generation Intel® Core™ U series. To enable faster responsiveness and deal with multi tasks with ease, the CS-W115FHC/P2102 is equipped with two DDR4 2400 SODIMM sockets for up to 64 GB memory.

With its slim design, the CS-W115FHC/P2102 offers extensive I/O to fulfill different connectivities and can easily fit into almost any space limited environment. For wireless connectivity, the CS-W115FHC/P2102 has 1x M.2 2230 E key and 2x full-size Mini-PCIe expansions which can be installed various add-on cards to enable Wi-Fi, 3G, and LTE communication. Besides, the CS-W115FHC/P2102 supports Control Function Module (CFM) Technology to install optional CFM modules for increasing power over ethernet and power ignition sensing functions according to user's specific applications. Featuring rigorous industrial protections, wide range operating temperature (-10°C to 70°C), IP65 dust/waterproof front panel, and wide range DC power input (9 to 48VDC), the CS-W115FHC/P2102 is appropriate for tough outdoor applications under direct sunlight.

Furthermore, the CS-W115FHC/P2102 supports Cincoze patented Convertible Display System (CDS) technology, allowing users to replace display module or computer module on-site easily and thereby reducing maintenance costs and downtime.

Specifications

Display

LCD Size	• 15.6" (16:9)
Max. Resolution	• 1920x1080 (Full HD)
Brightness (cd/m2)	• 1,500
Contrast Ratio	• 700:1
LCD Color	• 16.7M
Pixel Pitch (mm)	• 0.17925 (H) x 0.17925 (V)
Viewing Angle (H-V)	• 160 /140
Backlight MTBF	• 50,000 hrs (LED Backlight)

Touch

Resistive 5-wire	-
Projected Capacitive	V

System

Processor	<ul style="list-style-type: none"> • Onboard 8th Intel® Core™ U Processors (Whiskey Lake) - Intel® Core™ i5-8365UE Quad Core Processor (6M Cache, up to 4.10 GHz) - Intel® Core™ i3-8145UE Dual Core Processor (4M Cache, up to 3.90 GHz) - TDP: 15 W
Memory	<ul style="list-style-type: none"> • 2x DDR4 2400 MHz 260-Pin SO-DIMM Socket • Supports up to 64 GB (un-buffered and non-ECC)

Graphics

Graphics Engine	• Integrated Intel® UHD Graphics 620
Maximum Display Output	• Supports Triple Independent Display (via VGA and DisplayPort Outputs)

Audio

Audio Codec	• Realtek ALC888-GR
Line-out	• 1x Speaker-out Phone Jack 3.5mm
Mic-in	• 1x Mic-in, Phone Jack 3.5mm

External I/O Interface

VGA	• 1x VGA (1920 x 1200 @60Hz)
DP	• 1x DisplayPort (4096 x 2304 @ 60Hz)
LAN	• 2x GbE LAN (Supports WoL, Teaming, Jumbo Frame & PXE), RJ45 - GbE1: Intel® I219-LM - GbE2: Intel® I210
USB	• 3x USB 3.2 Gen2 (Type A) • 2x USB 2.0 (Type A)
COM	• 4x RS-232/422/485 with Auto Flow Control (Supports 5V/12V), DB9

DIO

DIO	• 16x Isolated DIO (8x DI/8x DO), 20-Pin Terminal Block
-----	---

Storage

SSD/HDD	• 2x 2.5" HDD/SSD Drive Bay (SATA 3.0)
RAID	• Supports RAID 0/1

Expansion

M.2 Express	• 1x M.2 2230 E Key for Socket Wireless Module, Supports Intel CRF Module
Mini PCI Express	• 2x Full-size Mini-PCIe Socket
SIM Socket	• 1x Front Accessible SIM Socket
CFM (Control Function Module) Interface	• 2x Control Function Module (CFM) Interface

Other Function

Internal Speaker	• AMP 2W + 2W
Power Ignition Sensing	• 1x Ignition DIP Switch (12V/24V, need to work with CFM module)
Clear CMOS Switch	• 1x Clear CMOS Switch
Rest Button	• 1x Reset Button
Instant Reboot	• Supports Instant Reboot Technology (0.2 sec)
Watchdog Timer	• Software Programmable Supports 256 Levels System Reset
OSD Function	• LCD On/Off, Brightness Up, Brightness Down

Power

Power Button	• 1x ATX Power On/Off Button
Power Mode Switch	• 1x AT/ATX Mode Switch
Power Input	• 9 - 48VDC, 3-pin Terminal Block
Remote Power On/Off	• 1x Remote Power On/Off Connector, 2-pin Terminal Block
Power Adapter (Optional)	• AC/DC 12V/5A 60W or AC/DC 24V/5A 120W

Physical

Dimension (W x D x H)	• 420 x 254 x 79 mm
Weight Information	• 6.25 Kg
Mechanical Construction	• Rugged Aluminum Die-casting Front Bezel and Heavy Duty Metal Chassis
Mounting	• Panel / VESA / *Rack Mounting (*with optional mounting kit)
Physical Design	• Fanless Design • Jumper-less Design

Reliability & Protection

Reverse Power Input Protection	• Yes
Over Voltage Protection	• Protection Range: 51~58V • Protection Type: shut down operating voltage, re-power on at the preset level to recover
Over Current Protection	• 15A
Surge Protection	• 3.84 kV (impedance 12 ohm 1.2/50µs waveform)
CMOS Battery Backup	• SuperCap Integrated for CMOS Battery Maintenance-free Operation
ESD Protection	• +/-8kV (air), +/-4kV (contact)

Operating System

Windows	• Windows® 10
Linux	• Support by Project

Environment

Operating Temperature	• -10°C to 70°C (with Extended Temperature Peripherals; Ambient with Air Flow)
Storage Temperature	• -20°C to 70°C
Relative Humidity	• 95% RH @ 39°C (Non-condensing)
Shock	• Operating, 15 Grms, Half-sine 11 ms Duration (w/ SSD, according to IEC60068-2-27)
Vibration	• Operating, 1.5 Grms, 5-500 Hz, 3 Axes (w/ SSD, according to IEC60068-2-64)
EMC	• CE, FCC, ICES-003 Class A
IP Level	• IP65 Compliant Front Panel

External Layout

Front I/O

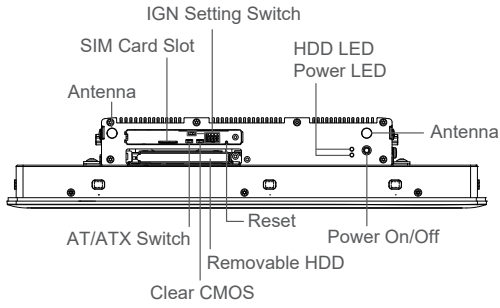

Rear I/O

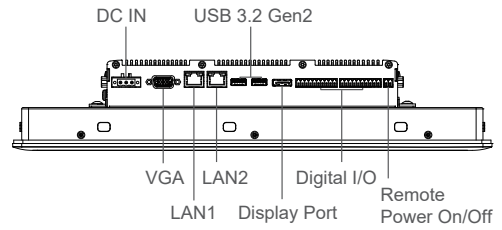

Left I/O

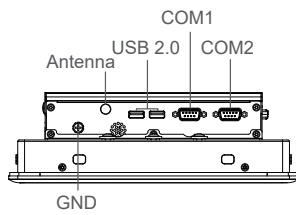

Right I/O

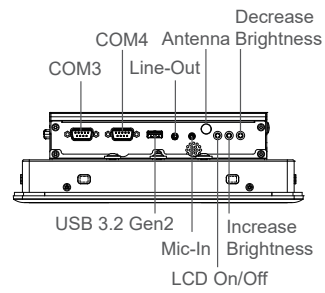

Dimensions

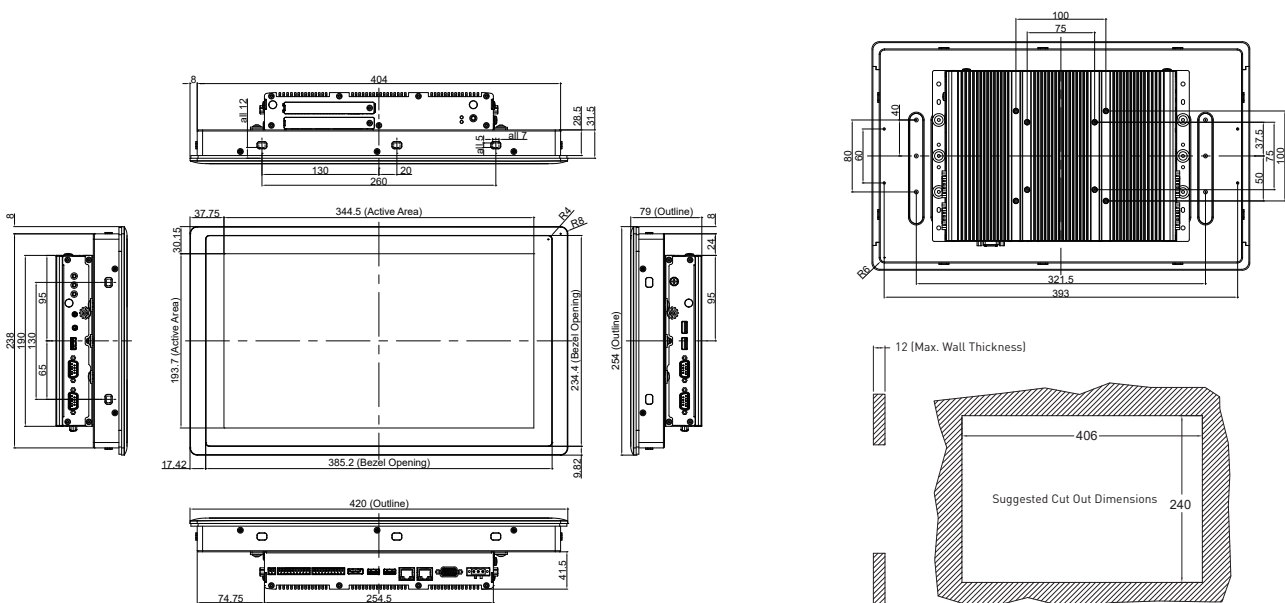

Unit: mm

Ordering Information

Available Models

Model No.	Description
CS-W115FHC-R10/P2102-i5-R10	15.6" TFT-LCD Modular Panel PC with 8th Gen. Intel Core i5-8365UE Quad Core Processor and P-Cap. Touch
CS-W115FHC-R10/P2102-i3-R10	15.6" TFT-LCD Modular Panel PC with 8th Gen. Intel Core i3-8145UE Dual Core Processor and P-Cap. Touch

Package Checklist

- CS-W115FHC/P2102 Panel PC x 1
- Thermal Pad (for CPU Thermal Block) x 1
- Power Terminal Block Connector x 1
- Remote Power On/Off Terminal Block Connector x 1
- DIO Terminal Block Connector x 2
- Utility Driver DVD x 1
- Screws Pack x 5
- Panel Mounting Kit x 1

Optional Modules

Model No.	Description
CFM-IGN101	CFM Module with Power Ignition Sensing Control Function, 12V/24V Voltage Detection Selectable
CFM-PoE04	CFM Module with PoE Control Function, Individual Port 25.5W
URM01	Universal 19" Rack Mount Kit for Industrial Panel PC & Industrial Monitor

Optional Accessories

Model No.	Description
GST60A12-CIN1	Adapter AC/DC 12V 5A 60W, GST60A12-CIN1, wide temp (-30°C ~ +70°C), level VI
GST120A24-CIN	Adapter AC/DC 24V 5A 120W, GST120A24-CIN, wide temp (-30°C ~ +70°C), level VI

Assured Systems

Assured Systems is a leading technology company with over 1,500 regular clients in 80 countries, deploying over 85,000 systems to a diverse customer base in 12 years of business. We offer high-quality and innovative rugged computing, display, networking and data collection solutions to the embedded, industrial, and digital-out-of-home market sectors.

US

sales@assured-systems.com

Sales: +1 347 719 4508
Support: +1 347 719 4508

1309 Coffeen Ave
Ste 1200
Sheridan
WY 82801
USA

EMEA

sales@assured-systems.com

Sales: +44 (0)1785 879 050
Support: +44 (0)1785 879 050

Unit A5 Douglas Park
Stone Business Park
Stone
ST15 0YJ
United Kingdom

VAT Number: 120 9546 28
Business Registration Number: 07699660